

WRXLink^{G3}

Engine Management

Plug-in sequential fuel and ignition control

WRXLink Ver. 7-9

Installation Manual

Board V1.7 23-01-07

Link ElectroSystems Ltd. Warranty Statement

Effective 5pm, April 5th, 1992
All products manufactured or distributed by Link ElectroSystems Ltd. Are subject to the following, and only the following, LIMITED EXPRESS WARRANTIES, and no others
For a period of one (1) year from and after the date of purchase of a new Link ElectroSystems Ltd. Product, Link ElectroSystems Ltd. Warranties and guarantees only to the original purchaser / user that such a product shall be free from defects of materials and workmanship in the manufacturing process. A product claimed to be defective must be returned to the place of purchase. Link ElectroSystems Ltd., as its sole option, shall replace the defective product with a comparable new product or repair the defective product. This expressive warranty shall be inapplicable to any product not properly installed and properly used by the purchaser – user or to any product damaged or impaired by external forces. This is to the extent of warranties available on this product. Link ElectroSystems Ltd. Shall have no liability whatsoever for consequential damages following from the use of any defective product or by reason of the failure of any product. Link ElectroSystems Ltd. Specifically disclaims and disavows all other warranties, express or implied including, without limitation, all warranties of fitness for a particular purpose (except for those which apply to product or part thereof that is used or bought for use primarily for personal, family or household purposes), warranties of description, warranties of merchantability, trade usage or warranties of trade usage.

Link ElectroSystems Ltd. License Agreement

The programme in this system is licensed not sold. Link ElectroSystems Ltd. Grants you a license for the programme only in the country where you acquired the programme. You obtain no rights other than those granted under this license. Under this license you may use the programme on only one machine at a time. If you transfer the programme you must transfer a copy of this license and all other documentation. Your license is then terminated. You may terminate your license at any time. Link ElectroSystems Ltd. May terminate your license if you fail to comply with the terms and conditions of this license. In either event you must destroy your copy of the programme.

By Link ElectroSystems Ltd.

© Link ElectroSystems Ltd. 2006

CONTENTS

1 – INTRODUCTION.....	3
1.1 – LINK SUPPORT.....	4
1.2 – SAFETY FIRST.....	4
2 – INSTALLATION.....	5
2.1 – ECU INSTALLATION.....	5
3 – FIRST TIME SETUP.....	11
3.1 – CONNECTION TO PCLINK.....	11
3.2 – INITIAL ADJUSTMENTS.....	14
3.2.1 – BASE CONFIGURATION.....	14
3.2.2 – MAP SENSOR CALIBRATION.....	14
3.2.4 – TPS CALIBRATION.....	15
3.2.5 – IAT SENSOR SELECTION.....	15
4 – WRXLINKG3 EXCESS (XS) CONNECTOR.....	17
APPENDIX A – DEFAULT CONFIGURATION.....	18

1 – INTRODUCTION

Thank you for purchasing your Link ElectroSystems Ltd. Plug-In Engine Control Unit (ECU). Link G3 ECU's are an advanced, fully programmable microprocessor controlled Engine Management System. The WRXLink^{G3} is the second generation of the successful range of PossumLink ECU's now based on the new G3 software platform.

The G3 software platform boasts an impressive list of features giving a new level of user adjustment. This flexibility allows the tuner to have complete control over the engine management system. G3 software employs high resolution (up to 440 zone) fuel and ignition tables with configurable load and RPM centers. When coupled with four dimensional fuel and ignition mapping, barometric pressure compensation and intake air temperature correction this gives an unprecedented level of tuning accuracy. The G3 platform also includes full variable valve timing (VVT) control and advanced motorsport features. All G3 ECU's are in field upgradeable, there is no need to return the unit for software updates.

All Link Plug-In Engine Management Systems are designed with minimum installation in mind. Link Plug-In systems replace the circuit board inside the factory ECU enclosure. This provides an unobtrusive means of fitting a fully programmable engine management system to your vehicle without any permanent modifications and a completely invisible install.

Link Engine Management Systems are designed with the final result in mind. Not only do they boast an impressive range of performance features, but are designed with a focus on safety, reliability and drive-ability. However, the ultimate success of your engine management upgrade is determined by how well the system is installed and tuned.

1.1 – LINK SUPPORT

Link ElectroSystems Ltd. appreciates your custom and has full confidence that you will be satisfied with your engine management system upgrade. Should any issue arise or for technical assistance the following support options are available:

- Contact your nearest Link Dealer (a dealer list is available on our website).
- Link ElectroSystems Website – www.LinkECU.com
- Technical Support Email – tech@LinkECU.com
- Online Discussion – www.LinkECU.com/forums

1.2 – SAFETY FIRST

Your Link Plug-In ECU is designed to enhance the performance of your vehicle. However in all cases, your vehicle must be operated in a safe manner. Do not tune your vehicle while operating it on public roads. Obey road rules at all times.



Failure to follow all installation and operating instructions may result in damage to the Link ECU, personal injury, or harm to property.

2 – INSTALLATION

The following sections describe physical installation of the WRXLink^{G3} ECU and required sensors:

2.1 – ECU INSTALLATION

The WRXLink^{G3} is designed to be installed in place of the printed circuit board in the factory ECU. This creates a completely invisible install and eliminates the need to modify ECU mounting points.

WARNING

The following installation process will require handling of both the Link ECU and factory ECU. Both of these are highly sensitive to electrostatic discharge and are easily damaged. Follow the anti-static precautions given in this manual carefully to avoid damaging electronic components. Warranty claims for ECU's damaged by electrostatic discharge will NOT be accepted.

ANTI-STATIC HANDLING GUIDELINES

Your body builds up an electrical charge as you move around. This charge can reach very high voltages. Whenever given the opportunity this energy will attempt to discharge (usually through your finger tips!). This can be fatal to most electronic components. Most people have experienced an electrostatic discharge when they step out of their car or touch a metal bench top.

The following guidelines describe precautions that can be taken to reduce the possibility of damaging your ECU:

1. Work only on a conductive surface. A clean steel bench is suitable.
2. Always wear a wrist strap that is electrically connected to the conductive working surface.
3. Touch the working surface regularly.
4. Do NOT touch components on the circuit board.
5. Where possible, only handle the ECU by its plastic header.
6. Do NOT carry the ECU around without static packaging (the black box supplied with the Link ECU is static protective).
7. Do NOT touch the bare terminals in the ECU header.

Observing the above procedures will minimise the chance of damaging both the factory and Link ECU's. Note that failure due to static damage often does not appear until well after it was caused.

Pre-Installation Configuration:

A wiring change between Sti and WRX models means that the WRXLink^{G3} must be pre-configured for your vehicle. Unfortunately this wiring change is not consistent between all models so no hard and fast rule applies to which setup is required. The ECU is configured by moving the configuration jumpers as shown below:

	<p style="text-align: center;">Option 1</p> <p>J6 – Always fitted J2 – Fitted J3 – Fitted J4 – NOT Fitted J5 – NOT Fitted</p>
	<p style="text-align: center;">Option 2</p> <p>J6 – Always fitted J2 – NOT Fitted J3 – NOT Fitted J4 – Fitted J5 – Fitted</p>

Do not fit the jumpers in any position other than the ones shown above. No harm will be caused to the ECU by installing the jumpers in the wrong option and fitting the ECU to the vehicle. If the ECU does not power up try the other jumper

option. If the ECU fails to power up with the jumpers fitted in either of the option positions, another problem exists.

Installation Procedure:

1. Remove the factory ECU from the vehicle: The factory ECU is located on the passengers side floor under a protective metal plate (under the carpet where the passengers feet would rest). Remove any necessary interior panels to lift the carpet to expose the metal plate that covers the ECU. Remove the 6mm bolts (10mm socket) that retain the metal plate and remove the plate from the vehicle. Unplug the wiring harness from the factory ECU (press the locking button on each connector while gently pulling on it). Remove the 6mm bolts (10mm socket) that retain the ECU and remove the ECU from the vehicle. **DO NOT** touch the exposed pins in the factory ECU connector.
2. Remove the factory ECU from its enclosure: Ensure you are following the given anti-static guidelines and **ARE WEARING A CONDUCTIVE WRIST STRAP** connected to the working surface. Remove the top cover from the ECU enclosure by removing the **five** retaining screws. Remove the circuit board, holding it only by the plastic header and place it aside.
3. Fit the Link Plug-In ECU: Remove the Link ECU from its packaging and place it on the lower part of the ECU enclosure. Place the factory ECU in the packaging your Link ECU came in for its protection. Fit the top cover to the ECU enclosure. Fit the four corner retaining screws. If you plan to tune the vehicle immediately, then screw the circuit board down without the top cover. There will

be one screw left over after installation. Screw this into the top of the factory ECU's metal heat-sink for safe keeping.

4. Fit the ECU back to the vehicle: Fit the ECU back into the vehicle in the reverse order to which it was removed. If the top cover is not fitted, just sit it on during fitting to vehicle to prevent any ECU damage.

2.2 – INTAKE AIR TEMP SENSOR INSTALLATION

In installations where the Mass Air Flow (MAF) meter is to be removed, it is highly recommended that an Intake Air Temp (IAT) sensor should be installed to allow for precise fueling correction as air temperature changes.

Note: Some models from 2003 onwards (STI) have an intake air temperature sensor installed from factory in the intake manifold. This sensor is wired to the ECU and connected to AN Temp 4.

Almost any NTC thermistor type IAT sensor can be installed. It is recommended to use a Bosch open element IAT sensor to ensure a known calibration and fast response. This sensor and its wiring connector can be purchased from any Link dealer.

Note: Installation of the IAT sensor will require modification to the intake system. A threaded boss must be welded into the intercooler or intake pipes. This requires correct equipment and should only be performed by a professional installer.

Install the IAT sensor in the intake system between the throttle body and intercooler outlet. The sensor should be installed as close as is practical to the throttle body.

The IAT sensor will be wired to the original air flow meter wiring. IAT sensor wires must be properly soldered and insulated. It is recommended that the IAT wires are soldered to the air flow meter wires approximately 30 mm behind the air flow meter connector. It is not necessary to cut the wires, but rather strip back a 10 mm section of insulation. Figure 2.2 shows wiring connections:

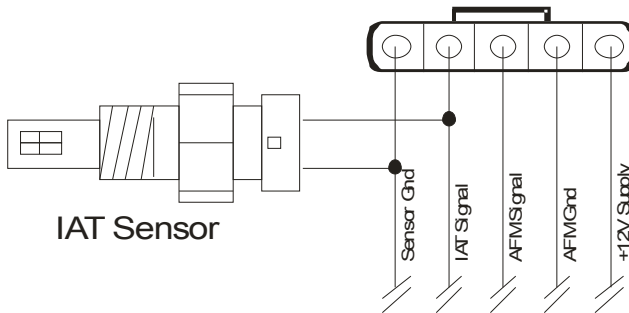

Looking into **back** (wire side) of the Air Flow Meter Connector

Figure 2.2 – WRXLink^{G3} IAT Sensor Wiring Connections

After wiring is completed, it is essential that the air flow meter connector is tied back in a manner that makes it impossible for it to be connected back to the air flow meter. Connecting both the IAT Sensor and air flow meter could result in damage to the air flow meter and will result in tuning problems that could cause engine damage.

3 – FIRST TIME SETUP

Although Link ECU's come with base settings that allow the engine to be started, ALL Link ECU's must be professionally tuned immediately after installation. Failing to have the ECU correctly tuned for your vehicle could result in engine damage or violation of emissions laws.

3.1 – CONNECTION TO PCLINK

PCLink is Link ElectroSystems Ltd. ECU tuning software. This software must be installed on a Windows based laptop/notebook before any adjustments or tuning can be performed. The latest version of PCLink is freely available for download from:

www.LinkECU.com

Link G3 ECU's come with on board USB support. Before connecting your Link ECU to a laptop/notebook PC for the first time, the communications drivers must be installed. These drivers tell the PC how to talk to the ECU. USB Drivers for Link ECU's are also freely available for download from the above website.

Driver installation instructions are also available from the above website (right next to the driver download). These should be followed closely. Should any problems arise, contact one of the support options given in Section 1 of this manual.

After installing both PCLink and the Link USB drivers, the ECU can be connected to the PC. Connect the ECU to the PC using a standard USB cable (these fit most printers and are available from Link dealers) as shown in Figure 3.1

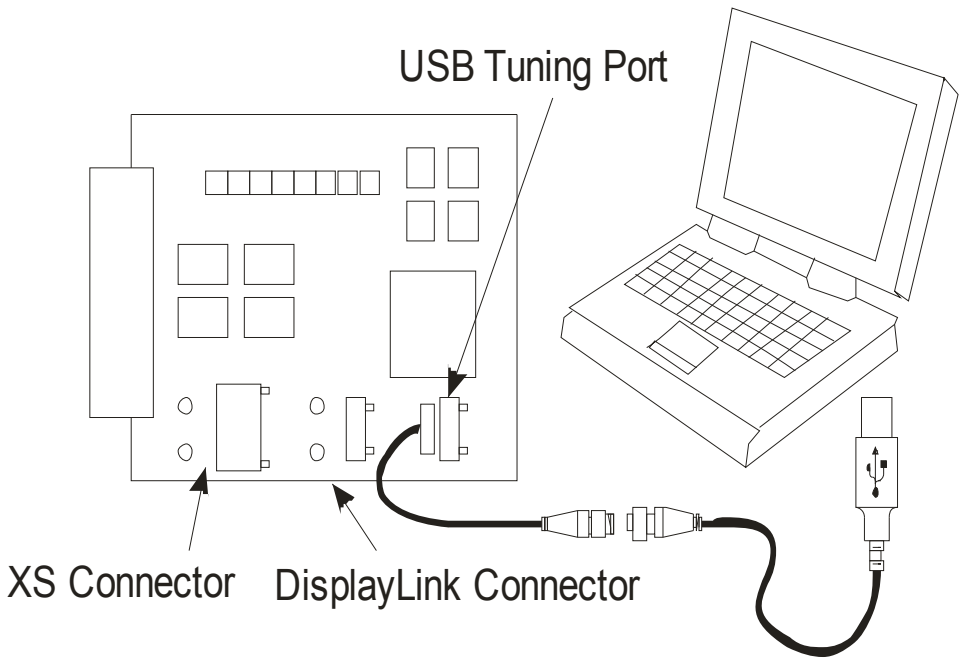

Figure 3.1 – WRXLink^{G3} Tuning Cable Connection

After connecting the ECU to the PC, run PCLink. Under the 'Options' menu select the correct COM port for communications with the Link ECU. This COM port number should have been determined during the Link ECU USB driver setup. If the COM port number is unknown, it may be necessary to try all COM ports until the correct one is found. Select 'OK' to close the 'Options' window.

To connect to the Link ECU, turn on the ignition switch then click on the L symbol (top center of screen). All settings should now be loaded from the ECU and the Link logo in the top right corner of the screen should be spinning to indicate communications are OK. If an error occurs during connection, recheck all wiring connections and ensure the correct COM port is selected.

If connection can not be established, contact one of the support options given in Section 1 of this manual.

Help on individual tuning functions is available through the PCLink on line help (Press F1, or right click on any item and select 'Whats This?').

3.2 – INITIAL ADJUSTMENTS

It is important that the procedures described in the following sections are followed before the Link ECU is tuned.

3.2.1 – BASE CONFIGURATION

All WRXLink G3 ECU's are shipped with base configuration settings for a V7 vehicle. PCLink includes base configurations for V7, V8 and V9 vehicles. Download the appropriate base configuration into your ECU with PCLink by selecting 'Open' under the 'File' menu. Select the appropriate .pcl file and then select 'Open'. Downloading large configuration files can take up to a few minutes. Be patient and acknowledge any messages the PCLink shows.

3.2.2 – MAP SENSOR CALIBRATION

The following procedure must be performed before tuning to ensure that the MAP Sensor is correctly calibrated. This is done by calibrating the MAP sensor to the ECU's internal Barometric Absolute Pressure (BAP) sensor. The BAP sensor is calibrated before the ECU is shipped. To calibrate the MAP sensor:

1. Connect a laptop/notebook PC to the ECU and connect to the ECU using PCLink as described in Section 3.1.
2. Under the 'Options' menu, select 'MAP sensor calibration'.
3. Follow the on screen instructions.
4. Select the 'Analog Inputs' tab in the runtime values section of PCLink (lower part of the screen).

5. Compare the MAP and BAP values and ensure they have a similar reading (within 1 kPa).
6. Perform a 'Store' by clicking on the S button (top center of screen) and clicking OK.

3.2.4 – TPS CALIBRATION

The Throttle Position Sensor (TPS) is used by the ECU to calculate various engine management parameters. It is important that the ECU knows when the throttle is open and closed (or part way in between). The following procedure calibrates the ECU to match the TPS:

1. Connect a laptop/notebook PC to the WRXLink G3 and connect to the ECU using PCLink as described in Section 3.1.
2. Under the 'Options' menu, select 'TPS calibration'.
3. Follow the on screen instructions.
4. Select the 'Analog Inputs' tab in the runtime values section of PCLink (lower part of the screen).
5. Ensure the Throttle Position value reads 0% when the throttle is closed and 100% when fully open.
7. Perform a 'Store' by clicking on the S button (top centre of screen) and clicking OK.

3.2.5 – IAT SENSOR SELECTION

Where a MAF meter (Air Flow Meter) is not being used, an Intake Air Temperature (IAT) sensor (installed in Section 2) is used by the Link ECU to calculate fueling corrections based on the engines intake air temperature. It is important that the WRXLink G3 is calibrated to

match the sensor installed in the engine. This procedure is as simple as selecting the correct sensor type as follows:

1. Connect a laptop/notebook PC to the WRXLink G3 and connect to the ECU using PCLink as described in Section 3.1.
2. Click on 'Analogue Channel' in the configuration tree (white area in top left corner).
3. Click on 'ANTemp2' in the configuration tree (Note some “Spec C” models have an IAT sensor wired to ANTemp4).
4. Ensure 'Temp Channel #2' is set to 'Inlet Air Temperature'.
5. Select the correct 'Temp Sensor Type'.
6. Select the 'Analog Inputs' tab in the runtime values section of PCLink (lower part of the screen).
7. Ensure that IAT reads the correct temperature.
8. Perform a 'Store' by clicking on the S button (top centre of screen) and clicking OK.

4 – WRXLINK^{G3} EXCESS (XS) CONNECTOR

As most of the WRXLink's input and output pins are configurable, these pins can be used to connect other devices simply by re-wiring them (eg if air con is no longer fitted, the air con clutch output could be used to drive a shift light).

To reduce the need for modification of the factory loom, some Link Plug-In ECU's have a connector that allows expansion of the ECU's input and output capabilities. The WRXLink's XS connector is located on the circuit board as shown in Figure 3.1. This connector allows the following additional inputs to be connected:

- 1 x Analog Inputs – 0-5V for wide band Lambda, pressure etc...
- 2 x Digital Inputs – for switches (e.g. Antilag, launch control etc...)

The WRXLink's XS connector does not have any additional output pins as these are all used by other functions.

As it is seldom used, the WRXLink^{G3} is not shipped with the XS connector wiring loom. Contact your nearest Link dealer to purchase a loom. Wiring instructions are included with the loom.

Note:

Do NOT attempt to connect anything to the WRXLink XS connector without using the purpose built wiring loom. Doing so may result in permanent damage to your Link ECU.

APPENDIX A – DEFAULT CONFIGURATION

The following table is a summary of the WRXLinkG3 input/output default configuration:

Auxiliary Drivers	
Aux 1	ISC Solenoid
Aux 2	VVT Solenoid (LH Inlet Cam)
Aux 3	VVT Solenoid (RH Inlet Cam)
Aux 4	Boost Control Solenoid
Aux 5	Rear Oxygen Sensor Heater
Aux 6	Tachometer
Aux 7	Engine Fan
Aux 8	Purge Solenoid
Digital Inputs	
DI 1	Vehicle Speed (Frequency)
DI 2	Cam Position (RH Inlet)
DI 3	Cam Position (LH Inlet)
DI 4	Air Con Request
DI 5	Neutral/Park
DI 6	Ignition Switch
DI 7	XS Connector
DI 8	XS Connector
DI 9	Blower Fan Switch
DI 10	IC Spray Switch
DI 11	Power Steer Switch
DI 12	Start Position
Analog Inputs	
An Temp 1	Engine Temperature

An Temp 2	Inlet Air Temperature
An Temp 3	Fuel Temperature
An Temp 4	Intake Temp (Spec C Models)
An Volt 1	XS Connector
An Volt 2	Rear Oxygen sensor
An Volt 3	Fuel Level
An Volt 4	Fuel Tank Pressure
An Volt 5	TGV LH
An Volt 6	TGV RH
Load 1	MAP
Load 2	MAF
Load 3	TPS

Ignition Channels

Ignition 1	Cylinder 1 Igniter
Ignition 2	Cylinder 2 Igniter
Ignition 3	Cylinder 3 Igniter
Ignition 4	Cylinder 4 Igniter
Ignition 5	Fuel Pump Relay
Ignition 6	Main Relay
Ignition 7	I/C Spray Relay
Ignition 8	Fuel Pump Speed

Injection Channels

Injection 1	Cylinder 1 Injector
Injection 2	Cylinder 2 Injector
Injection 3	Cylinder 3 Injector
Injection 4	Cylinder 4 Injector
Injection 5	A/C Clutch Relay
Injection 6	Check Engine Light
Injection 7	Fuel Tank Pressure Solenoid
Injection 8	A/C Fan Relay