

# Link

## Engine Management LEMV5e

# Wiring & Installation Manual

## Link ElectroSystems Ltd. Limited Warranties Statement Effective April 5, 1992 5 p.m.

All products manufactured or distributed by Link ElectroSystems Ltd. are subject to the following, and only the following, LIMITED EXPRESS WARRANTIES, and no others:

For a period of one (1) year from and after the date of purchase of a new Link ElectroSystems Ltd. product, Link ElectroSystems Ltd. warranties and guarantees only to the original purchaser - user that such a product shall be free from defects of materials and workmanship in the manufacturing process. A product claimed to be defective must be returned to the place of purchase. Link ElectroSystems Ltd., at its sole option, shall replace the defective product with a comparable new product or repair the defective product. This expressive warranty shall be inapplicable to any product not properly installed and properly used by the purchaser - user or to any product damaged or impaired by external forces. This is the extent of warranties available on this product. Link ElectroSystems Ltd. shall have no liability whatsoever for consequential damages following from the use of any defective product or by reason of the failure of any product. Link ElectroSystems Ltd. specifically disclaims and disavows all other warranties, express or implied including, without limitation, all warranties of fitness for a particular purpose (except for those which apply to product or part thereof that is used or bought for use primarily for personal, family, or household purposes), warranties of description, warranties of merchantability, trade usage or warranties of trade usage.

### Link ElectroSystems Ltd. Licence Agreement

The programme in this system is licensed not sold. Link ElectroSystems Ltd. grants you a license for the programme only in the country where you acquired the programme. You obtain no rights other than those granted under this license. Under this license you may use the programme on only one machine at any one time. If you transfer the Programme you must transfer a copy of this license and all other documentation. Your license is then terminated. You may terminate your license at any time. Link ElectroSystems Ltd. may terminate your license if you fail to comply with the terms and conditions of this license. In either event you must destroy your copies of the programme.

© Link ElectroSystems Ltd

# By Link ElectroSystems Ltd.



# Notice

Due to frequent upgrades, PCLink is no longer distributed on CD with new Link ECUs.

PCLink is available for free download at the following web site:

[www.linkecu.com](http://www.linkecu.com)

Should internet download not be practical, a copy of PCLink can be requested on CD from your nearest Link Dealer.

# Table of Contents

1. Introduction.....	5
2. Parts List .....	6
3. Choosing Functions.....	7
3.1 Injector Drives .....	7
3.2 Ignition Drives.....	7
3.3 Auxiliary Outputs .....	7
3.4 Analog Inputs .....	8
3.5 Triggering .....	9
3.6 Summary .....	9
4. Component Locations .....	10
4.1 ECU Placement .....	10
4.2 Ignition Component Placement .....	11
5. Breakout Loom .....	12
6. Power and Grounds.....	14
6.1 Switched +12V (RED) .....	14
6.2 Power Ground (BLACK) .....	15
6.3 Signal Ground (BLACK) .....	15
6.4 5V Out (RED / BLUE Stripe).....	15
6.5 +12V Out (RED/WHITE Stripe).....	15
7. Inputs .....	16
7.1 MAP Sensor .....	16
7.2 Trig1 and Trig2 (BLACK & GREY shielded cables).....	17
7.3 E Temp (YELLOW) .....	18
7.4 NBOxy (WHITE) .....	19
7.5 TPS In (WHITE / BLUE Stripe) .....	21
7.6 A Temp (GREEN / YELLOW Stripe).....	22
7.7 WBOxy (GREEN / WHITE Stripe) .....	23
7.8 Boost Adj (GREEN / BLUE Stripe) .....	24
8. Fuel Injector Drives (Inj1, Inj2) .....	25
8.1 Multi-Point Group Injection .....	25
8.2 Single Point Group Injection .....	27
8.3 Staged Injection.....	27
9. Ignition Drives (IG1, IG2 and IG3) .....	29
9.1 Igniter Requirements .....	30
9.2 Coil Requirements .....	31
9.3 Ignition Suppression .....	32
9.4 Distributor .....	33
9.5 Multi-Coil: Wasted Spark .....	34
9.6 Two-rotor rotary engines .....	37
10. Auxiliary Outputs (Pump, Fan, Aux1, IG3, Aux2).....	38
10.1 Pump (PURPLE) .....	38
10.2 Fan (BROWN / BLACK Stripe) .....	38
10.3 Aux1 (BROWN / WHITE Stripe) - Tachometer Drive .....	39
10.4 Aux1 (BROWN / WHITE Stripe) - Boost Control .....	39
10.5 Aux1 (BROWN / WHITE Stripe) - RPM Switch .....	45
10.6 Aux1 (BROWN / WHITE Stripe) - Idle Speed Control .....	46
10.7 Aux 1 (BROWN / WHITE Stripe) - Tachometer Drive .....	46
10.8 IG3 (BLUE / WHITE Stripe) - Shift Light .....	47
10.9 IG3 (BLUE / WHITE Stripe) - Tachometer Drive .....	47
10.10 Aux2 (GREEN / BLACK Stripe) .....	47

# 1. Introduction

Thank you for purchasing a LEMV5 Link Engine Management system. Your LEM is a fully adjustable management system designed to allow you to setup your engine for an optimal state of tune.

Installing and tuning any adjustable engine management system is not a small task, however the LEM has been designed to simplify the process as much as possible.

The complete setup of your LEM has been divided into two equally important tasks.

1. This manual covers the wiring and installation of your LEM. While it is not essential that this work is performed by an auto electrician, the knowledge and tools available to these professionals makes it highly recommended. Regardless of who ends up doing the work, it is of utmost importance that clean and robust connections are made throughout the installation. A significant majority of aftermarket engine management failures are due to poor wiring practices.
2. Once the LEM has been installed it will need to be tuned using either a Link Tuning Module or a laptop computer with PCLink software. Information on the configuration and tuning of a LEM is detailed in the 'LEMV5 – Configuration and Tuning manual'. The LEM is loaded with a base map that should be able to get your engine running after a few simple adjustments have been made. While hearing the engine running on the new ECU for the first time is always a satisfying feeling, it is important to realise that the job is not finished. The amount of tuning performed and the experience of the tuner are the two most important factors in determining how happy you will be with your engine management system.

If you are unsure about any part of the installation we are here to help. Feel free to contact your dealer or phone Link on ++64-3-348 8854 from outside New Zealand or 03-348 8854 from inside New Zealand or email [tech@link-electro.co.nz](mailto:tech@link-electro.co.nz)

A majority of the questions received by the technical support team are clearly answered in one of these two manuals. Therefore, please consult the manuals to make sure that your question has not already been answered.

## 2. Parts List

If your LEM V5 was purchased new it should contain the following:

- Link Engine Management (LEM) Engine Control Unit (ECU)
- LEM V5 - Wiring and Installation Manual (what you are reading)
- LEMV5 – Configuration and Tuning Manual-
- Four Mounting Screws and two Right Angle Brackets
- A CD containing PCLink
- A Link Engine Management Sticker

If a 2m or 5m loom was also purchased the second package should contain:

- 17-wire Loom
- 4-wire Loom (2m only)
- Ignition Suppressor
- Fuel Pump Relay

If your LEM was upgraded to V5 firmware you should have received your upgraded LEM, the two manuals and the CD. Note that older LEMs do not have the additional 4-pin connector. Because of this, the extra features provided by this connector will not be available.

# 3. Choosing Functions

As some of the LEM inputs and outputs are configurable and/or optional, the required connections will be dependant on the application. The first step in installing an LEM is to decide what function each of the configurable inputs and outputs will provide. Read this section carefully to ensure the correct functions are chosen.

## 3.1 Injector Drives

The LEM has 2 injector drives (Inj1 - brown, Inj2 - orange) and supports either group injection (where the injectors are fired together in groups) or staged injection (with a primary group of injectors that operates at all times and a secondary group of injectors that operates only at high load).

## 3.2 Ignition Drives

The LEM has 3 ignition drives (Ig1 – blue, Ig2 – blue with black stripe, Ig3 – blue with white stripe) which can be used to run up to an 8 cylinder engine using a distributor(s) or 4 and 6 cylinder engines using multiple coils fired in a wasted spark configuration. The range of available configurations are summarized in Table 3.0.

Number of Cylinders	Distributor	Wasted Spark
3	YES	NO
4	YES	2 Dual Post Coils
5	YES	NO
6	YES	3 Dual Post Coils
8	YES	NO

*Table 3.0 Supported Ignition Configurations*

IG3 is only used for 6 cylinder engines using wasted spark or for two-rotor rotary engines. Therefore, in all other cases IG3 may be configured to drive either a shift light or a tachometer.

## 3.3 Auxiliary Outputs

The LEM has 3 (or 4) auxiliary outputs.

The first auxiliary output (Pump - purple) is used to switch on the fuel pump relay.

The second auxiliary output (Aux1 - brown with white stripe) may be configured for one of the following:

- Electronic boost control (using a boost control solenoid)
- RPM switched (variable valve timing etc.)
- Idle Speed Control (using a 2-wire ISC solenoid)

If IG3 is used for ignition purposes, then Aux1 may only be used as a tachometer drive.

The third auxiliary output (Fan – brown with black stripe) is used to switch a relay for the radiator cooling fan.

Late model LEMs have a secondary four pin header which has an output (Aux2 - green with black stripe) that can be switched at a predetermined RPM, MAP, TPS or injector duty cycle.

## 3.4 Analog Inputs

The LEM has 3 (or 6) analog inputs.

The first analog input (E Temp – yellow) measures the engine coolant temperature using a common NTC water temperature sensor. This signal is used to enrich the air/fuel mixture when the engine is cold. Therefore, this input must be used in all cases.

The second analog input (NBOxy – white) is used as an input from a narrow-band oxygen sensor as fitted to most factory fuel injected engines.

The third analog input (TPS In – white with blue stripe) is used to measure the position of the throttle using a full-range throttle position sensor (TPS). This is used for acceleration enrichment, row selection when using the TPS or TPS+MAP Row Steps modes or if Aux1 is being used for idle-speed control.

Late model LEMs have a secondary four pin header which gives another 3 inputs. These have the following functions.

A Temp (green with yellow stripe) measures the temperature of the air entering the engine. This enables the LEM to make both fuel and ignition timing corrections for changes in air temperature. Air temperature may only be measured using the recommended sensor.

BoostAdj (green with blue stripe) may be connected to a variable resistance knob or an on/off switch to adjust the boost pressure on engines using electronic boost control.

WBOxy (green with white stripe) may be used as an input from the UEGOLink wide-band oxygen sensor controller for tuning and data-logging purposes.

### 3.5 Triggering

Trig1 (Black cable) and Trig2 (Grey cable) are required to input signals from a crank/cam angle sensor (CAS) or from the ignition coil negative on fuel only systems. These signals are used by the LEM to calculate the current engine speed and position.

### 3.6 Summary

By this stage you should understand what each of the inputs and outputs will be used for.

If the LEM does not support the desired configuration (for example if BOTH idle speed and electronic boost control are desired) then a Link dealer should be consulted for information on an ECU suitable for the application.

# 4. Component Locations

The LEM Engine Management System and associated components may be installed virtually anywhere but it is important to choose component locations in accordance with the following design rules.

## 4.1 ECU Placement

1. The LEM requires environmental protection for both physical and electrical factors that may affect its performance. Normally this requires the device to be fitted inside the vehicle cabin. This position avoids the high ambient temperatures associated with the engine bay and reduces the chances of the ECU getting wet. This position also offers some physical separation between the ECU and potential interference causing ignition components.
2. The main exception to this rule is where the engine is somewhat distant from the driving position, such as in a boat. In these cases the ECU should be mounted in close proximity to the engine but NOT directly on, or next to, the engine (e.g. mounted just outside the engine compartment). The idea here is to minimise the length of wiring between the engine and the ECU while maintaining some physical distance to prevent heat and strong interfering signals upsetting the ECU operation. It is preferable to have short main wiring and a longer tuning/adjustment cable.
3. If water immersion or spray is likely (particularly for marine applications), additional protection may be necessary. A sealing plastic container may be employed here.



*Fig 4.1 Example of waterproof enclosure*

4. Allow sufficient space at both ends of ECU for the main wiring harness, MAP sensor vacuum hose and tuning cables to be connected. The tuning port end of the LEM should remain accessible so that tuning cables may be inserted and removed.
5. Four M4 tapped holes in the sides of the enclosure provide a mounting point for brackets etc. DO NOT drill holes in the case, as this will probably cause internal damage.

## 4.2 Ignition Component Placement

All components of the ignition system have the potential to radiate large amounts of interference (electromagnetic radiation) that can wreak havoc on sensitive electronic devices. Therefore, it is essential that the ignition components are carefully placed and that full suppression techniques are used (see Section 9 - Ignition for further details).



**IMPORTANT** Never mount the igniter onto or next to the ECU

Always mount igniter(s) in the engine bay as close to the ignition coil(s) as possible. This helps to minimize the length of high current wiring between the igniter(s) and coil(s). Avoid areas of high temperature such as exhausts, turbochargers and radiators since the igniter itself will generate heat at high power. If vibration levels will be excessively high, some form of soft or rubber mounting is advisable to prevent component and wiring fatigue. Preferably igniters should be mounted on the chassis rather than the engine to reduce vibration.

# 5. Breakout Loom

The LEM can be supplied with a 17-pin 200mm, 2m or 5m long breakout loom. This is used to connect the required inputs and outputs to the LEM. Some connections are made directly to the relevant device, while others require some form of interface such a relay or ballast resistors.

Figure 5.0 illustrates the main header layout (& wire colours) when looking into the LEM connector.

17 Pin AMP Connector - Wire Side

Inj 1 Brown	Ig 1 Blue	Ig 2 Blue / Black	Ig 3 Blue / White		+12 V Red	Trig 1 Yellow <small>Black Screen</small>	E Temp Yellow	TPS In White / Blue
Inj 2 Orange	Pump Purple	Aux 1 Brown / White	Fan Brown / Black	P Gnd Black <small>2.00 mm</small>	S Gnd Black <small>1.25 mm</small>	Trig 2 Blue <small>Grey Screen</small>	NB Oxy White	5V Out Red / Blue

*Figure 5.0 LEM Pinout (looking into header)*

Late-model LEMs have a 4-pin connector that can be used to provide extra functionality. This connector is located next to the tuning port as shown in Figure 5.1. Older LEMs that have been upgraded with V5 software but do not have the connector may not use the extra features. A breakout loom which plugs into the 4-pin connector is available from a Link dealer.

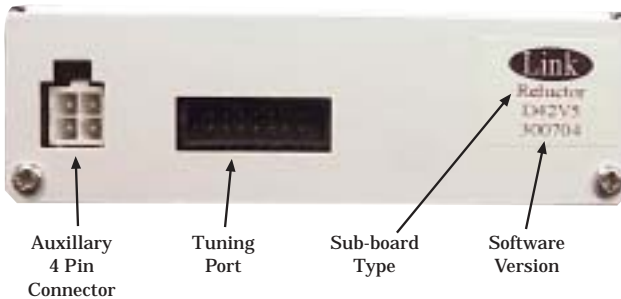

*Figure 5.1 4-pin connector*

Figure 5.2 illustrates the 4-pin header layout (& wire colours) when looking into the LEM connector.

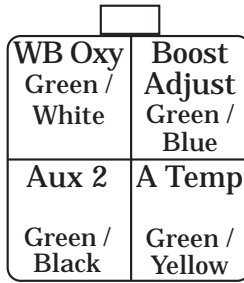

*Figure 5.2 4-pin Connector Pinout (looking into header)*

# 6. Power and Grounds

## 6.1 Switched +12V (RED)

The red wire is used to provide power for the LEM. It should be connected to a source that provides power when the key is in the 'ON' position. Do not use a source that provides power when the key is in the ACC position as these typically are cut while the starter motor is being cranked.

Although the ECU does not draw a large amount of current, the voltage applied to the 'Switched +12V In' wire must remain above 8V at all times. This is especially important while the starter motor is being cranked. A significant drop in voltage will result in the ECU undergoing a reset that will stop the engine from running. For this reason it is suggested that the ECU and other voltage critical devices are run from a relay connected directly to the battery. This relay should be switched on by an ignition switched 12V source. This arrangement is shown in Figure 6.0.

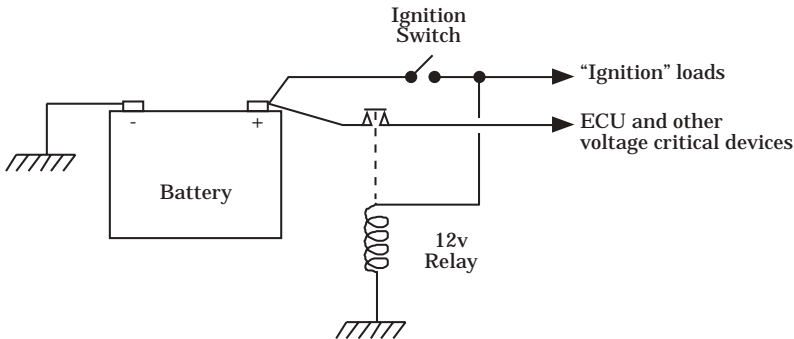

*Figure 6.0 Power Supply Relay Wiring*

Even with the configuration shown above it is important that the battery is in good condition and suitable for the application. Also, make sure that all wiring to the battery and associated terminals are clean and free from corrosion.

## 6.2 Power Ground (BLACK)

The wire supplies the high current earth to the output drives. Since this wire will carry substantial currents, ensure it is well terminated to a clean earth point on the engine block.

## 6.3 Signal Ground (BLACK)

This input supplies the low current earth supply for all low-level signal processing of the computer. It must be well terminated to a clean earth point on the engine block.



### IMPORTANT!

Signal Ground and Power Ground **MUST** be run as **SEPARATE** wires. **DO NOT** be tempted to join both together at the computer and run as a single wire. Also, beware of poor earth points around the engine. Some manifolds and other attaching parts may be rubber mounted and therefore have poor earth bonding. A good rule of thumb is to use the engine **BLOCK** rather than attaching parts.

## 6.4 5V Out (RED / BLUE Stripe)

This wire supplies a regulated 5V to be used for the throttle position sensor and boost adjustment knob. If both devices are being used the 5V Out wire must be shared.

## 6.5 +12V Out (RED/WHITE Stripe)

This wire supplies unregulated supply to optical or hall crank/cam angle sensors. The voltage may reach up to 15V depending on the charging system. Some sensors may work satisfactorily with voltages this high, however other sensors (especially hall sensors) require a regulated voltage of 5, 8 or 12V. In these cases an in-line voltage regulator must be used.

This wire will **NOT** be used if the engine uses retractor sensors. In this case care must be taken to ensure that this wire is insulated as it should never be allowed to make contact with any grounds.

# 7. Inputs

## 7.1 MAP Sensor

The manifold air pressure (MAP) sensor is inside the LEM and **MUST** be used in all applications. This should be connected to a source of vacuum (as well as pressure for turbo applications) via a suitable length of 3mm (7/64”) vacuum hose. The fuel pressure regulator air pressure port is usually a good takeoff point. This connection is shown in Figure 7.0. Do not be tempted to share the MAP sensor vacuum hose with other devices such as a boost gauge.

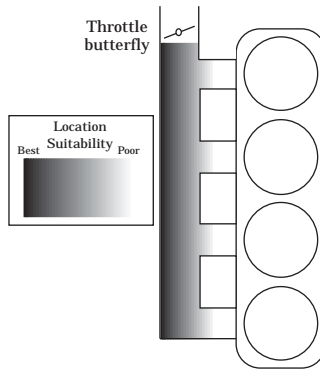

*Figure 7.0 Connection of vacuum hose to manifold and MAP sensor*

Multiple throttle valve (butterfly) engines will require a mini-manifold joining all intake runners on the engine side of the throttle valves. Never run the vacuum line to a single runner only.

The length of a dedicated vacuum line has relatively little effect on the ECU performance. Lengths of up to several meters long have been used successfully.

The LEM MAP sensor reads up to 250kPa absolute (1.5Bar of boost or approximately 22psi).

## 7.2 Trig1 and Trig2 (BLACK & GREY shielded cables)

Trigger inputs are required for the LEM to calculate the current engine speed and in some cases the current position in the firing order. In all applications Trigger 1 will be required. In some applications Trigger 2 will also be required to generate a sync pulse. These must be connected to the correct crankshaft or camshaft angle sensors to provide the required information.

Some applications using only Trigger 1 may not be able to use wasted spark. In these cases either a distributor must be used or a second sensor may be fitted to generate a sync pulse.

The trigger inputs are very important signals and must arrive at the ECU free of any noise or interference. For this reason shielded cables are used. These should also be kept as far as practically possible from noisy ignition components such as igniters, coils and HT leads.

There are a large number of triggering variants used by different engine manufacturers. The important differences are the type of sensors used, the number of pulses sent from the sensors during a revolution and the timing of the pulses in relation to the engine cycle.

If the current application was specified when the ECU was ordered then the correct sub-board will have been fitted inside the ECU. Therefore the only information required during the wiring stage is the type of sensors and which sensor each of the two trigger inputs should be connected to. **This information should have been included on a page inserted at the end of this manual.**

There are two types of sensors that are commonly used. It is important that the sensor type is known, as the wiring for each type is completely different.

Reluctor/magnetic sensors have a toothed trigger wheel that passes across the face of the sensor. These sensors usually have only two wires as the sensor itself generates a voltage. One wire is the ground while the other is the signal output. The polarity of the two wires is very important and must be correct. Some reluctor sensors have a second ground and therefore have three wires.

Optical/Hall sensors have a slot to allow teeth of a trigger wheel to pass through. These sensors typically have a trigger wheel with slits cut out of it to generate pulses. These sensors require a power supply and therefore have three wires.

Alternatively, fuel only systems (were the ignition is not controlled by the LEM) may be triggered using from the ignition coil negative, however the appropriate series resistor must be fitted.

The Trigger 1 and Trigger 2 cables each contain two wires surrounded by a braided shield. These have the following functions.

- **Trigger 1 Cable (BLACK)**  
Yellow - Trigger 1 signal input  
Brown - Ground  
Braided Shield - leave unconnected at sensor end
- **Trigger 2 Cable (GREY)**  
Blue - Trigger 2 signal input  
Green - Ground  
Braided Shield - leave unconnected at sensor end

+12V Out (RED/WHITE Stripe) - Optical/Hall Sensor power supply



The +12V Out wire will NOT be used if the engine uses reluctor sensors. In this case care must be taken to ensure that this wire is insulated as it should never be allowed to make contact with any grounds.

### 7.3 E Temp (YELLOW)

The engine coolant temperature is required for fuel mixture enrichment during an engines warm-up period.

The LEM measures engine coolant temperature using an NTC-type sensor. These sensors have a resistance that changes with temperature and are commonly used in automotive applications.

Normally the factory coolant temperature sensor is suitable and should be used if present. If the factory sensor is not suitable a sensor may be purchased from a Link supplier. This sensor should always be mounted on the engine side of the thermostat.

Connect the yellow ETemp wire to one of the terminals on the sensor. The other terminal should be connected to the engine block. The orientation of the two wires is not important.

## 7.4 NBO<sub>xy</sub> (WHITE)

There are many variations of narrow-band exhaust gas oxygen (EGO) sensors although all are identical in terms of the output signal. The principal differences are mostly physical involving lead tolerance, heated or unheated, mounting methods, and whether or not a signal ground wire is supplied.

### 7.4.1 Lead Tolerance

The lead additives used in most high octane (avgas or race gas) fuel will contaminate the probe over a period of time resulting in eventual probe failure. Lead tolerant (shielded) probes are available and must be used if long term exposure to leaded fuel is likely.

### 7.4.2 Heating

Many probes incorporate an electrical heating element, which is powered by the vehicles 12 Volt supply. These heaters allow the probe to be mounted in cooler portions of the exhaust system and significantly improve the probe performance at idle and during warm up phases of operation. This is because the probe temperature must exceed 300°C before accurate readings are possible.

### 7.4.3 Mounting

Most probes use a standardised M18 x 1.5 metric thread designed to screw into a mating boss. Some variants use a bolted flange arrangement, but these are relatively uncommon.

Almost all EFI engines will have a probe installed as original equipment in the exhaust manifold or turbo housing.

If the vehicle does not have a factory fitted EGO sensor, it will be necessary to manufacture a sensor mount according to engine type and layout.

The ideal mounting position of the sensor in the exhaust can vary depending on the application.

Most of the time the preferred position is in the exhaust manifold (highest temperature) although a location further down the exhaust is acceptable

provided the probe is adequately heated. Note that not all probe heaters were created equally. Some are considerably more powerful than others ranging from about 7 to 18 watts. Probes of Japanese origin tend to have lower powered heaters and should be located as close as practical to the manifold. European probes (eg. Bosch) tend to have higher heater power.

The lead tolerant versions tend to have higher heater power, which enables them to work right back at the tail pipe.

Note that it is also possible to get an EGO sensor too hot. If the probe temperature exceeds 700°C then the sensor reading becomes inaccurate. Therefore in applications with particularly high exhaust gas temperatures (e.g. turbo engines, rotary engines) it may be necessary to either use an unheated sensor or move a heated sensor further down the exhaust.



**Caution:** Lambda Probes use ceramic material internally and are susceptible to impact damage. Handle probes carefully to avoid impacts at all times.

#### 7.4.4 Sensor Wiring

Typically narrow-band EGO sensors can be recognised as having one, two, three or four wires. These have the following functions.

**Single Wire Sensor** - The wire is the signal output and should be connected directly to the Analog Input. Note that a ground wire should be run from the body of the sensor to the engine block, as the exhaust manifold may not adequately conduct.

**Two Wire Sensor** - One wire is the signal output and should be connected to the Analog Input. The other is the signal ground and should connect to the engine block.

**Three Wire Sensor (Heated)** - One wire for the signal output (to Analog Input). Two wires for the heater. One of the heater wires should be connected to an ignition switched 12V supply. The other heater wire can be connected to a convenient ground. Heater polarity is not important. Note that a ground wire should be run from the body of the sensor to the engine block, as the exhaust manifold may not adequately conduct.

**Four Wire Sensor (Heated)** - As for three wire sensor, but with an extra wire for the signal ground which must be connected to the engine block.

The recommended narrow-band EGO sensor is a Bosch 3-wire lead-tolerant unit with Part Number 0 258 003 070. As with other Bosch 3 wire sensors, the wire colours are:

2 white wires	=	heater (18 watts)
1 black wire	=	output signal
body	=	signal ground

Some other common types are listed below:

Nissan — red and black (heater), white (output signal), sensor body (signal ground)

Honda — 2 black wires (heater), white (output signal), green (signal ground)

## 7.5 TPS In (WHITE / BLUE Stripe)

A Throttle Position sensor is connected directly to the throttle shaft on the butterfly. Ensure the mounting position allows the TPS to move through its range as the throttle is opened.

Throttle Position is required for the following functions:

- Acceleration enrichment
- Idle Speed Control
- Zone table row selection (in some modes)

A typical TPS has 3 terminals. To wire either the factory TPS or a custom fitted sensor, an ohmmeter is required. Two of the terminals will show a fixed resistance as the TPS is moved. Connect one of these terminals to the 5V Out wire while the other terminal should be grounded on the engine block. The orientation of the +5V and ground does not matter. The result is that the TPS output will either increase or decrease in voltage with throttle position. As the LEM will automatically detect this either option is acceptable. The third terminal must show a variable resistance between the +5V and the ground terminal. This is the TPS output and should be connected to the Throttle Position Sensor wire on the LEM. Refer to Figure 7.1.

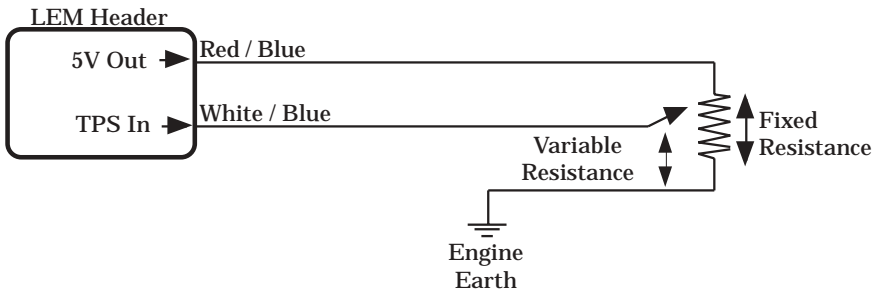

*Figure 7.1 TPS Schematic.*



**IMPORTANT** On some factory systems a throttle switch is used instead of a variable resistance. This can **NOT** be used with the LEM. If a TPS based function is required, a variable resistance TPS must be fitted to the throttle shaft.

**The following inputs refer to the 4-pin connector which is only available on newer models.**

## 7.6 A Temp (GREEN / YELLOW Stripe)

Using an inlet air temperature sensor allows fuel and ignition corrections to be made for changes in the temperature of the air entering the engine. The air temperature sensor must be setup to most accurately measure the temperature of the air entering the combustion chambers of engine. On a naturally aspirated engine this normally means any position between the air filter and inlet manifold. However, on a turbocharged/supercharged engine the sensor **MUST** be placed **AFTER** the turbocharger and any intercooler.

On most applications (both naturally aspirated and turbocharged) the recommended mounting position is the inlet pipe before the throttle plate. The sensor may also be placed in a section of the inlet manifold that is subject to high airflow. However, in some applications the inlet manifold may get very hot and heat soak the sensor causing a reading that is not representative of the air entering the combustion chambers.

It is very important (especially on a turbocharged/supercharged engine) that the air temperature sensor can react fast enough to track the rapidly changing temperature. It is also very important that a sensor with the correct calibration curve is used. For this reason it is essential that **ONLY** the air temperature sensor recommended by Link is used. This sensor is available from a Link dealer and is shown in Figure 7.2.



*Figure 7.2 Bosch Air Temperature Sensor*

To wire the air temperature sensor connect one terminal of the sensor to the A Temp wire. The other terminal of the sensor should be grounded on the engine block.

## 7.7 WBOxy (GREEN / WHITE Stripe)

This option requires a wide-band oxygen sensor and a wide-band controller module such as the UEGOLink or similar. The wide-band controller **MUST** have a 0-5V linear output with the following calibration.

$$0V = 9.0:1$$

$$5V = 19.0:1$$

The output and ground wire from the wideband controller must be connected to the WBOxy input and Signal Ground (or engine block) as shown in Figure 7.3.

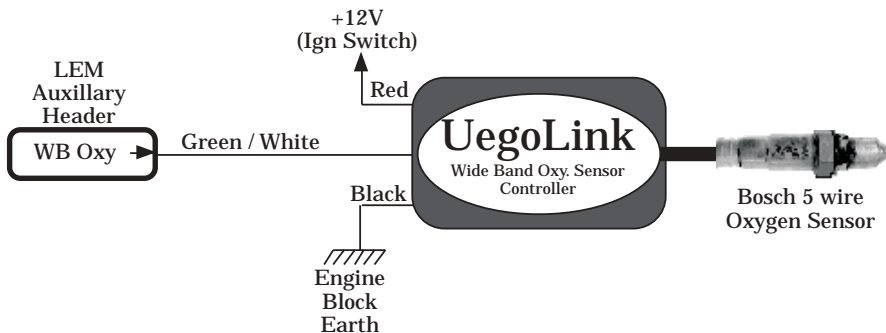

Figure 7.3 Wiring of Wide-Band Controller

## 7.8 Boost Adj (GREEN / BLUE Stripe)

Connecting a boost adjustment knob allows for on-the-fly adjustment of boost pressures for turbocharged engines using electronic boost control. Boost Adj is a 0-5V input which can be connected to a 1K ohm potentiometer to give boost adjustment. 0V on Boost Adj will give maximum boost, whilst 5V on Boost Adj will give minimum boost. Figure 7.4 shows how to wire the potentiometer.

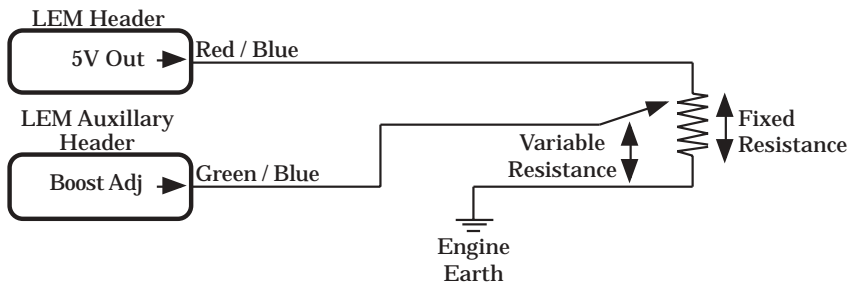

Figure 7.4 Wiring of Boost Adjustment Knob

## 8. Fuel Injector Drives (Inj1, Inj2)

The LEM has two injector drives named Inj1 (brown) and Inj2 (orange). The injector drives work by supplying an EARTH to turn the injectors on. A switched (key ON) 12V must be supplied to the other terminal on the injector. The polarity is not important.



DO NOT connect +12V directly any of the injector drives.



Injectors are commonly available as either high impedance or low impedance. Either type may be used with the LEM, however low impedance injectors **MUST** be used with ballast resistors.

Use an ohmmeter to measure the resistance across the two terminals of the injector. If this is greater than 6 Ohms then the injectors are high impedance and no ballast resistors are required. If this is less than 6 Ohms the injectors are low impedance and external ballasting will be required. The type of ballasting will depend on injector resistance and fuel mode. It should be noted that ballast resistors and their heat sinks get quite hot at high injector duty cycles. Take this into consideration when mounting these devices.

### 8.1 Multi-Point Group Injection

The injectors may be connected in a single group and fired using one injector drive. Alternatively the preferred option is to split the injectors into pairs with each pair being fired by one injector drive. The two injector drives fire at opposing times to smooth out fuel delivery. This helps to improve throttle response and reduces fuel pressure fluctuations.

#### 8.1.1 High Impedance Injectors

Up to 6 high impedance injectors may be run off each injector drive. However, for 8 cylinder engines the injectors **MUST** be split into two groups. The injectors may be wired directly to the injector drives as shown in Figure 8.1.

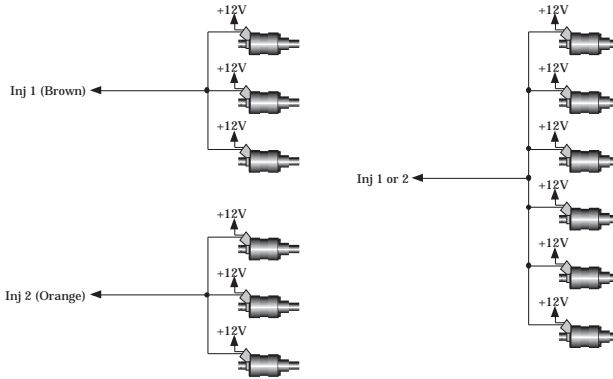

*Figure 8.1 Multi-Point Injection with High Impedance Injectors*

### 8.1.2 Low Impedance Injectors

If the injector resistance is less than 6 ohms then ballasting is required. In most applications factory ballasting can be used. The same wiring configurations can be used as described for high impedance injectors (6 injectors or less per injector drive). The only exception is the insertion of a ballast resistor between the LEM and injector group. This configuration is shown in Figure 8.2.

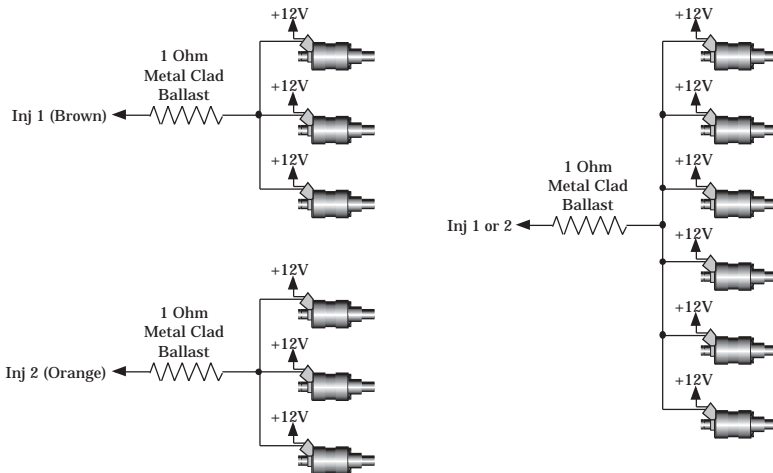

*Figure 8.2 Multi-Point Injection with Low Impedance Injectors*

## 8.2 Single Point Group Injection

The preference is to use two injectors with each one driven off of its own injector drive.

### 8.2.1 High Impedance Injector

If the injector resistance is greater than 6 ohms, no ballasting is required. The injector may be wired directly to the injector drive as shown in figure 8.3.

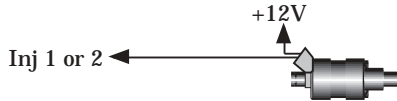

*Figure 8.3 Single Point Injection with High Impedance Injector*

### 8.2.2 Low Impedance Injector

If the injector resistance is less than 6 ohms then ballasting is required.

If the injector resistance less than 2 ohms use a 2R2 ballast.

If the injector resistance is between 2 and 6 ohms use a 4R7 ballast.

Figure 8.4 shows how to wire the low impedance injectors.



*Figure 8.4 Single Point Injection with Low Impedance Injector*

## 8.3 Staged Injection

Staged injection uses both a primary and secondary group of injectors. The primary group of injectors operates at all times while the secondary group of injectors operates only at high load. This enables the use of relatively small primary injectors to offer precise injector control at idle and low loads, while larger secondary injectors may be used to meet large fuel supply requirements at high loads.

On a typical multi-point setup each cylinder uses its own primary injector. Ideally each cylinder will also have its own secondary injector as well. It is possible to use a single secondary injector, however it is important that

the injector is placed to feed all cylinders equally. Wiring is the same as for Multi-Point Group Injection (Section 8.1) except that INJ1 drives the primary injectors while INJ2 drives the secondary injectors. Also remember that no more than 6 injectors may be driven from each drive. This restriction means that Staged Injection may only be used on multi-point engines which have 6 cylinders or less.

## 9. Ignition Drives (IG1, IG2 and IG3)

The LEM has 3 ignition drives named IG1 (blue), IG2 (blue with black stripe) and IG3 (blue with white stripe). This allows it to run distributed engines as well as 4 and 6 cylinder engines using a wasted-spark multi-coil configuration. The configurations shown in Table 9.0 are supported by the LEM.

Number of Cylinders	Ignition Type	IG1 Function	IG2 Function	IG3 Function	Aux1 Function
2-8	Distributor	Normal Ignition	Inverted Ignition	Shift Light OR Tacho	Boost OR RPM Switch OR Idle Speed
4	Wasted Spark	Ignition Channel 1	Ignition Channel 2	Shift Light OR Tacho	Boost OR RPM Switch OR Idle Speed
6	Wasted Spark	Ignition Channel 1	Ignition Channel 2	Ignition Channel 3	Tacho
2 RE	Wasted Leading Direct Trailing	Ignition Channel 1	Ignition Channel 2	Ignition Channel 3	Tacho

*Table 9.0 Ignition Configurations*

The exception is dual-distributor engines such as some of the Toyota/Lexus V8 engines. These use two ignition channels (IG1 and IG2). DO NOT use distributor mode as IG2 will undesirably be an inverted version of IG1.

The LEM also supports two-rotor rotary engines using the factory multi-coil setup with a dual-post leading coil and two trailing coils. These ignition systems require all three ignition channels.

There are 4 DIP switches on the main circuit board (not the sub-board). Normally these are set as:

- 1 = ON
- 2 = OFF
- 3 = OFF
- 4 = ON

If 3-channel ignition is being used (6-cylinder wasted-spark or 2-rotor engines) then these DIP switches MUST be set as:

- 1 = OFF
- 2 = ON
- 3 = ON
- 4 = OFF

When 3-channel ignition is being used Aux1 may only be used as a tachometer drive. Therefore Boost Control and Idle Speed Control may not longer be used.

## 9.1 Igniter Requirements

An igniter acts as an interface between the LEM and the ignition coil(s). The Igniter is used to fire the coil(s) by supplying a ground for the coils negative terminal. The igniter requires a ground connection to source ignition coil current. This wire should be connected directly to the engine block. A link igniter is shown in Figure 9.0.

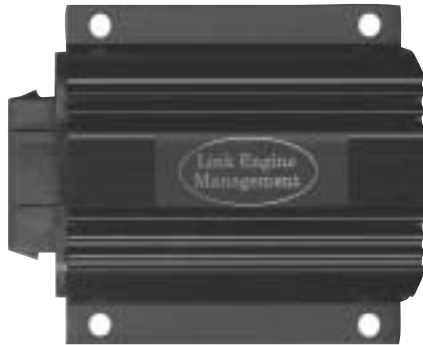

*Figure 9.0 Link Igniter*

The igniter is basically a solid state switch, which also limits the coil current to a predetermined value. This limiting feature eliminates ballast resistors and provides consistent output over a wide range of battery voltages. Over voltage clamping is incorporated to prevent damage to the igniter should a high-tension lead become disconnected or similar.

DO NOT connect the ignition drives directly to 12V, as this will cause permanent damage.

Each one of the 3 ignition drives on the LEM may be used to switch a separate channel on an igniter. Each channel on the igniter is used to switch an ignition coil.

Example - 4 cylinder engine with wasted spark

- Two ignition drives must be used
- A dual channel igniter must be used
- Two Dual Post Coils must be used

Example - 6 cylinder engine with wasted spark

- Three ignition drives must be are used
- A three channel igniter must be used
- Three dual post coils must be used

Example – engine with a single distributor driven ignition

- Only one ignition drive is used
- A single channel igniter must be used
- One Single Post Coils must be used

Always mount igniter(s) in the engine bay as close to the ignition coil(s) as possible. This helps to minimize the length of high current wiring between the igniter(s) and coil(s).



**NEVER** mount the igniter(s) next to the LEM

Avoid areas of high temperature such as exhausts, turbochargers and radiators since the igniter itself will generate heat at high power. If vibration levels will be excessively high, some form of soft or rubber mounting is advisable to prevent component and wiring fatigue.

## 9.2 Coil Requirements

Low resistance coils (approximately 1 Ohm or less) must be used for maximum output energy although higher resistance types may still function satisfactorily. This applies to both single and dual post coils in distributed and multi coil applications.

## 9.3 Ignition Suppression

Without exception ALL ignition systems must be suppressed. Failure to do so will cause the ECU to behave erratically, especially at high power. Symptoms include misfiring, erratic RPM readings and the ECU performing repetitive resets. The following rules must be followed.

- Unsuppressed H.T. leads act as aerials and radiate very powerful interference signals. ALL applications must use suppression leads, preferably resistance type rather than spiral wound or inductive. Typically these vary from 1000 ohms to 5000 ohms depending on lead length. NEVER use plain wire leads.
- ALL applications must also employ a suppressor capacitor (0.5 - 3uF) connected directly between the ignition coil(s) POSITIVE terminal and ground. Most points condensers are suitable. Multiple coils can share a single suppressor. 'V' and boxer engines must have a suppressor on each bank. Multiple suppressors per bank may improve suppression in some cases.
- Isolate the ignition system as much as possible from other sensitive devices, especially the ECU. Do not run non-ignition related wiring close to igniters, coils or HT leads wherever possible. Maintain maximum distance from radio transmitters and coaxial cables etc.
- Spark plugs used with dual post coils (wasted spark) MUST be resistor type plugs. Failure to observe this will result in medium/high power misfire due to uneven spark energy distribution.
- Reducing spark plug gaps often cures high power misfires especially on turbo/super charged engines. Gaps as small as 0.5mm (.020") may be necessary. This also reduces the amount of radiated energy due to the lower firing voltage.
- Keep the input wiring to the igniter (from the ECU) separate from the output wiring of the igniter (to the coil(s)) as shown in Figure 9.1.

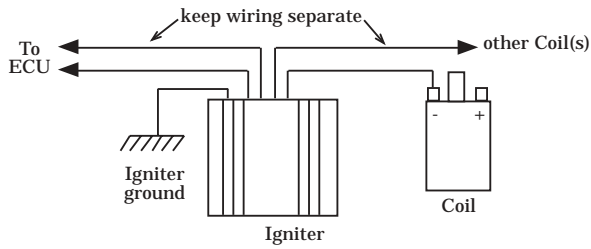

*Figure 9.1 Separation of igniter input and output wiring*

## 9.4 Distributor

A distributor rotates at half the crankshaft speed and routes the high voltage generated by the coil to the intended spark plug via a rotor and HT wiring. A distributed engine requires one ignition drive and a single channel igniter.

**IG1 (Blue)** – Use this drive with conventional igniters. The coil charges when the drive output is high. Spark occurs when the drive output makes the transition from high to low. All Link igniters use this method.

**IG2 (Blue/Black)** – Use this drive with inverted-type igniters that charge when the drive output is low. Spark occurs when the drive output makes the transition from low to high. These igniters are found on Honda and some Ford engines.

Note that IG3 may be used as a tachometer drive or a shift light. See Sections 10.7 and 10.8.

Igniter wiring on a distributed engine is shown below in Figure 9.2.

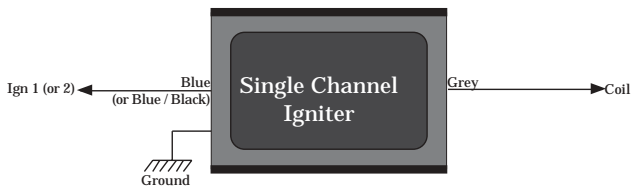

*Figure 9.2 Igniter wiring for distributed engine*

## 9.5 Multi-Coil: Wasted Spark

In this mode two cylinders will be fired simultaneously, using a common dual post coil. One cylinder is fired conventionally on the compression stroke while the other cylinder has its piston in the same position but on the exhaust stroke. One crankshaft rotation later, these two cylinders are two working strokes further ahead and the spark plugs fire again, but now with reversed roles. The result is that one spark plug is always being fired when required while another plug is fired with a wasted spark.

This setup can **ONLY** be used on engines with an even number of cylinders. The maximum number of cylinders the LEM can drive on wasted spark is 6.

One dual post coil (with a primary resistance less than or equal to 1 ohm) is required per 2 cylinders. Figure 9.3 shows a typical coil. The coils should be positioned so they minimise the length of the HT Leads. This will help reduce the noise generated when the spark plugs are fired.



*Figure 9.3 Dual Post Coil*

All dual post coils should be used with resistive spark plugs. Without resistive plugs the spark plug with the least load (the one on the exhaust stroke) tends to steal more spark energy resulting in a medium/high power misfire.

The main concern when using wasted spark is the generation of interference. When two spark plugs are fired together there is twice the spark energy generated and hence twice the radiation produced per engine TDC. This noise level increase can interfere with ECU operation and cause unwanted static on car radios. The ignition suppression techniques outlined earlier are particularly important.

It is possible to use a single post coil per cylinder rather than using dual post coils. However, each coil must be driven by its own igniter channel. In this case each ignition drive with fire two igniter channels.

To ensure each ignition drive is matched to the correct cylinder, the firing order will need to be determined. The firing sequence is simply the firing order starting with the first cylinder to fire after the sync pulse. In most cases the location of the sync pulse on a given engine will be shown in the application specific data inserted at the end of this manual.

Consider a four cylinder engine with firing order 1-3-4-2 and a sync pulse occurring between cylinders 3 and 4. The firing sequence would be 4-2-1-3.

Table 9.1 shows which ignition drive is used to fire each cylinder. In the left column 1st represents the first cylinder in the firing sequence and so on.

Cylinder in Firing Order	Number of Cylinders	
	4	6
1st	Ig1	Ig1
2nd	Ig2	Ig2
3rd	Ig1	Ig3
4th	Ig2	Ig1
5th		Ig2
6th		Ig3

*Table 9.1 – Wasted spark pairing of cylinders to ignition drives*

Example - Wasted spark setup for a 4 cylinder engine with 1-3-4-2 firing order and sync between 2 and 1.

- Ignition Drive 1 fires cylinders 1 and 4
- Ignition Drive 2 fires cylinders 2 and 3

Figures 9.5 and 9.5 show wiring for 4 and 6 cylinder engines with wasted spark. All setups show Link Igniter modules, although most factory igniters can be used.

## 4 Cylinder

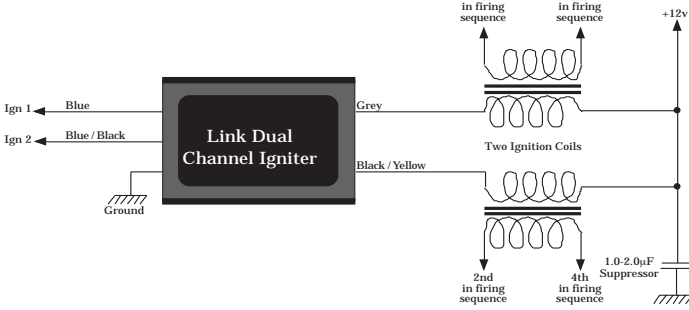

Figure 9.4 Wasted Spark on a 4 Cylinder Engine

## 6 Cylinder

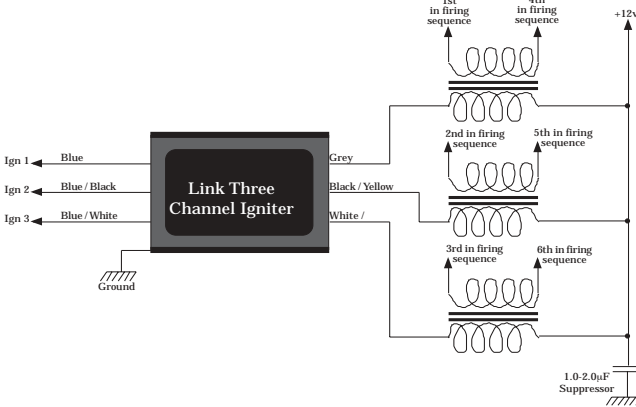

Figure 9.5 Wasted Spark on a 6 Cylinder Engine

## 9.6 Two-rotor rotary engines

The LEM supports two-rotor Mazda rotary engines using the factory multi-coil setup with one dual-post leading coil and two single-post trailing coils.

The LEM uses Ig1 to fire the two leading plugs, Ig2 to fire the rear trailing plug and Ig3 to fire the front trailing plug. In some cases the factory igniter may be used. If the factory igniter is not suitable (or not available) then a Link 3-channel igniter may be used.

The 86-91 RX7 factory ignition uses igniters which are built into the base of the coil brackets. The single-channel leading igniter is suitable and may be driven straight from Ig1. The dual-channel trailing igniter must be driven using an unconventional toggle arrangement. The LEM DOES NOT support this igniter. This igniter MUST BE REPLACED with a conventional dual-channel igniter (available from your Link dealer).

The factory igniter on the 92+ RX7s is a conventional 3-channel igniter and may be used if available.

If the LEM was ordered for a rotary engine then information on igniter wiring should have been inserted at the end of this manual.

# 10. Auxiliary Outputs (Pump, Fan, Aux1, IG3, Aux2)

The LEM has three auxiliary outputs named Pump, Fan and Aux1. All auxiliary outputs are designed to supply a GROUND. IG3 may be used to drive a shift light or tachometer if not required for ignition purposes.

DO NOT connect +12V directly to any auxiliary outputs

## 10.1 Pump (PURPLE)

Pump is used to switch on the fuel pump relay. The fuel pump is primed when the key is first turned on. The pump then runs only while an RPM signal is being received. Therefore the pump will automatically turn off when the engine stops. Wire the fuel pump and relay as shown in Figure 10.0.

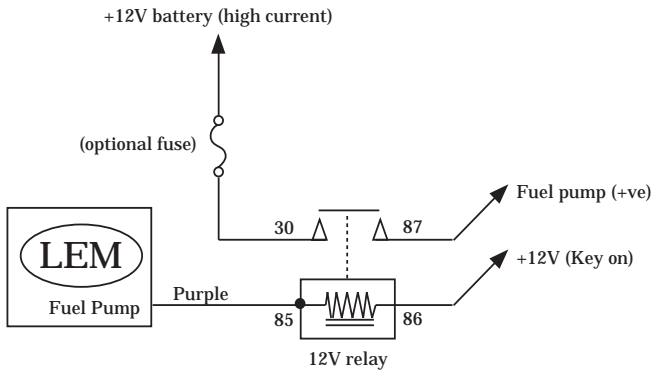
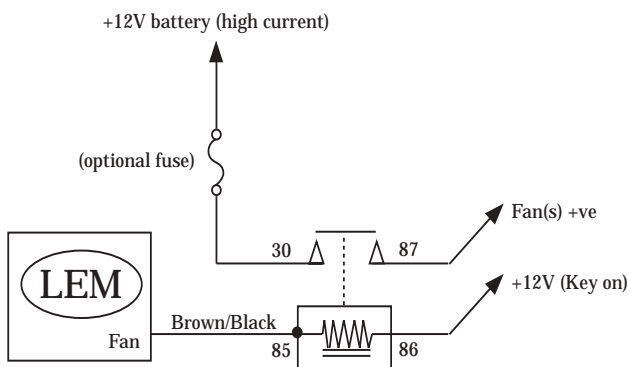

Figure 10.0 Wiring of Fuel Pump and Fuel Pump Relay

## 10.2 Fan (BROWN / BLACK Stripe)

Fan switches a relay for an electric radiator cooling fan when the engine coolant temperature exceeds a preset value. The fan will continue running until the temperature has fallen 4 degrees below the preset value. This helps to eliminate short fan cycles. Wire the cooling fan and relay as shown in Figure 10.1.



*Figure 10.1 Wiring of Cooling Fan and Relay*

### 10.3 Aux1 (BROWN / WHITE Stripe) - Tachometer Drive

If IG3 is being used for ignition purposes (6-cylinder wasted spark or rotary engines), then Aux1 may only be used as a tachometer drive.

### 10.4 Aux1 (BROWN / WHITE Stripe) - Boost Control

Electronic boost control is achieved by modifying the pressure signal from the turbocharger compressor outlet to the wastegate actuator using a solenoid.

The minimum boost pressure that can be achieved occurs when the solenoid is de-energised. This pressure is entirely dependent on the wastegate/actuator construction.

The maximum boost pressure that can be achieved occurs when the solenoid is energised. This pressure is dependent on the turbocharger/engine combination. Typically this pressure exceeds that which can be safely tolerated by the engine.

By varying the on/off ratio (duty cycle) of the boost control solenoid, a boost pressure between the minimum and maximum (outlined above) can be achieved. Since the ECU measures the manifold air pressure (MAP), this information is used to sense the current boost pressure so that changes are continuously made to achieve the target boost pressure.

## 10.4.1 Integral Wastegate with Three Port Solenoid

Figure 10.2 shows the recommended three-port solenoid for use with integral wastegates. These can be supplied by a Link dealer.

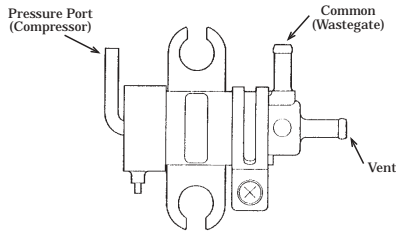
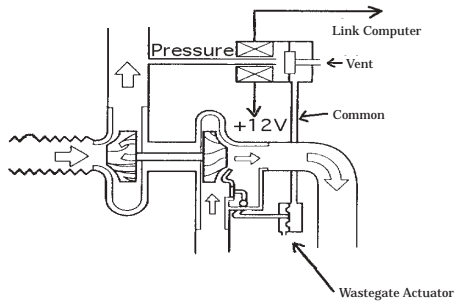

*Figure 10.2 Nippon Denso Three-port Solenoid for use with an Integral Wastegate*

This solenoid should be connected as described below and shown in Figure 10.3.

- common port is connected to the wastegate actuator
- pressure port is connected to the turbocharger's compressor outlet
- bleed port is vented to the atmosphere (usually via a filter)

When the solenoid is de-energised the common and pressure ports are connected and compressor pressure is allowed to fill the actuator and open the wastegate. When the solenoid is energised the common and vent ports are connected and the air pressure in the actuator is bled off to atmosphere.



*Figure 10.3 Fitment of three-port solenoid to Integral Wastegate*

### 10.4.2 Integral Wastegate with Two Port Solenoid

Some factory-fitted boost control systems use a simple two-port solenoid rather than the three-port type previously described (especially Nissan and Mitsubishi). These basically work as variable bleed and require some form of restrictor between the turbocharger's compressor (pressure source) and the boost control solenoid. This is shown in Figure 10.4.

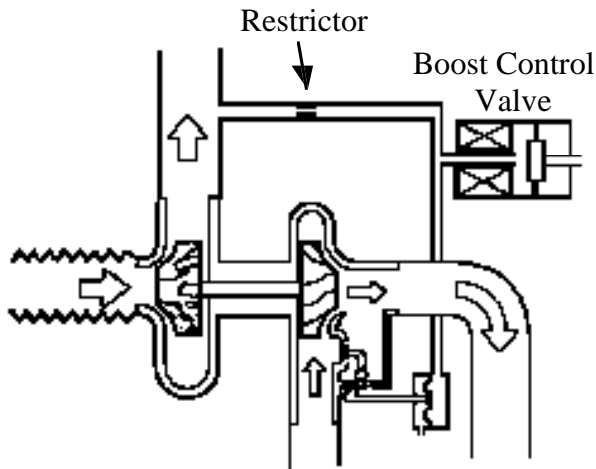

*Figure 10.4 Fitment of two-port solenoid to Integral Wastegate*

A typical size for the restrictor is 1.00 to 1.50 mm in diameter. The required size varies as it is dependent on factors such as the wastegate construction, the length of the hose and the diameter of the hose.

If the restrictor is too small then boost will tend to overshoot since it limits the rate at which the wastegate will fill and therefore move the actuator arm. If the restrictor is too large the ECU will be unable to achieve high boost operation. This is because the solenoid is unable to bypass sufficient pressure so the wastegate opens prematurely.

It is recommended that two-port solenoids are only used for small to moderate increases in boost pressures over the factory setting while the three-port types may be used for high boost applications requiring more precision and better control.

### 10.4.3 External Wastegate

In some applications, a factory-fitted integral wastegate in its fully open position may be unable to bypass a sufficient amount of exhaust gas to maintain the desired boost pressure. This condition is typically recognised when boost pressure rises uncontrollably at high engine speeds. In this case a larger diameter wastegate is required. Typically fitting an external wastegate is the easiest solution.

While both types of wastegates perform the same function, external wastegates have some important differences when compared to integral wastegates. Typical external wastegates actuators pull to open the wastegate rather than pushing it. Therefore, pressure must be applied to the bottom side of the diaphragm to open the wastegate. Either the 2-port or 3-port solenoids designed for integral wastegates can be used as long as the connection to the wastegate actuator is made beneath the diaphragm. However, this method is not recommended.

The preferred option is to use a second line from the compressor outlet to the topside of the actuator. It is recommended that the top and bottom of the wastegate actuator are fed by separate pressure lines. The boost control solenoid is then plumbed into the line connected to the top of the actuator as shown in Figure 10.5.

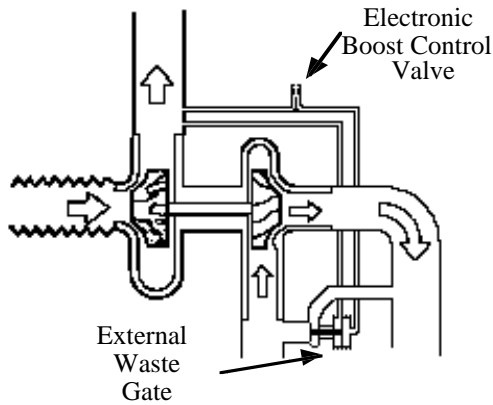

*Figure 10.5 Fitment of three-port Parker solenoid to External Wastegate*

However, the sense of operation is reversed with this system. Applying more pressure to the topside of the actuator CLOSSES the wastegate and INCREASES boost pressure. Therefore a solenoid with reversed sense is required. This solenoid must allow the top of the wastegate actuator to vent to atmosphere when de-energised, and fill the top of the actuator with boost pressure when energised. Figure 10.6 shows the Parker solenoid that is suitable for this application. Conventional two-port and three-port solenoids may not be used.

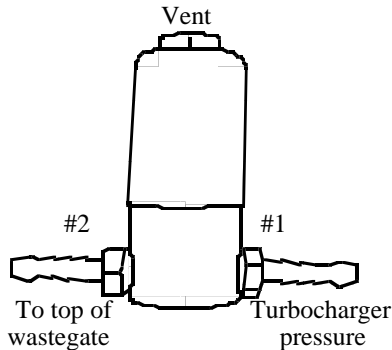

*Figure 10.6 Parker Solenoid for use with External or Integral Wastegates*

Port #1 is plumbed to the turbocharger, while port #2 is plumbed to the top of the wastegate.

### 10.4.4 Wiring & Mounting of Boost Control Solenoid

It is important that the correct type of solenoid is used. Devices intended for electronic boost control should be used wherever possible. Some types of plastic bodied units may work effectively but may not withstand the constant cycling imposed upon them and subsequently fail after several hours of service.

A solenoid's operation can be checked by blowing through its ports with the solenoid both energised and de-energised.

The solenoid should be mounted in the engine compartment as close to the Waste Gate as possible. This will keep the pressure line to the solenoid as short as possible and minimise any signal delay.

Aux1 on the LEM connects directly to one terminal on the solenoid to provide an EARTH, while the other terminal on the solenoid must be connected to an ignition switched (key ON) 12V source. This is shown in Figure 10.7. The orientation does not matter.

**STOP** Ensure diode 'D3' has been removed on the LEM main circuit board when using boost control.

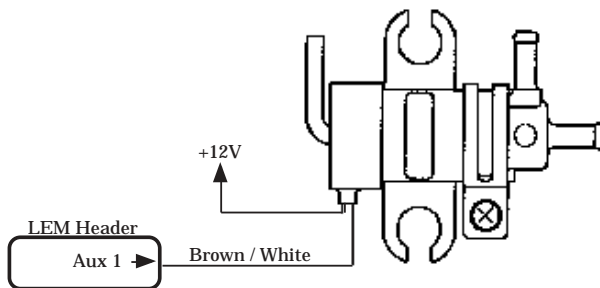

*Figure 10.7 Wiring & Mounting of Boost Control Solenoid*

## 10.5 Aux1 (BROWN / WHITE Stripe) - RPM Switch

This allows a load to be switched on at a certain engine speed. Aux1 will become active at the preset value. Typically this is used to control intake manifold runners, VTEC, cam control etc. Note that Aux1 may also be configured to switch off again at a preset engine speed.

On a typical two terminal solenoid, Aux1 should be connected to one terminal of the solenoid to supply a ground, while the other terminal should be connected to an ignition switched (key ON) 12V source. Note that the solenoid or bulb should have a resistance greater than 5 ohms. Loads with lower resistances must use a relay.

Some single terminal solenoids are grounded through the engine block (e.g. most Honda VTEC solenoids). Therefore 12V must be applied to the terminal on the solenoid to turn it on. An external relay may be used to 'invert' the signal in these cases.

Figure 10.8 shows how to wire a two terminal solenoid or light, while Figure 10.9 shows how to wire a single terminal solenoid.

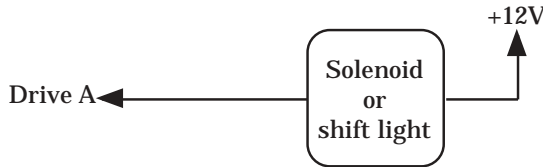

*Figure 10.8 Wiring for two terminal solenoid or light*

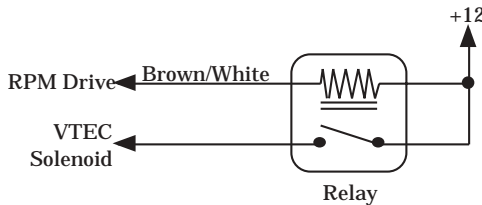

*Figure 10.9 Wiring for a single terminal solenoid*

## 10.6 Aux1 (BROWN / WHITE Stripe) - Idle Speed Control

The LEM can be wired to provide idle speed control using a two-terminal idle speed control (ISC) solenoid. These work by bypassing air around the throttle plate to increase the idle speed.

Connect one terminal of the ISC solenoid to Aux1. Connect the other terminal to a switched +12V supply. The wiring for a two-terminal ISC solenoid is shown in Figure 10.10. The orientation of the wires does not matter.



Ensure diode 'D3' is installed on LEM main circuit board when using Idle Speed Control.

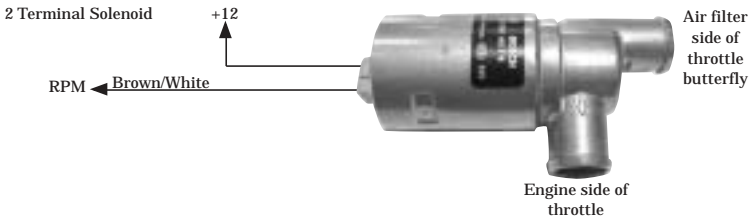

*Figure 10.10 Wiring for two-terminal ISC solenoid*

Some engines use a non-electronic system to control idle speed as the engine warms up. These systems contain a bimetallic strip, which is heated by the engine coolant and/or electrically. As the engine warms up, the amount of bypassed air is reduced and the idle is returned to its normal level. The LEM cannot control this type of device. They are intended ONLY as an idle up when the engine is cold.

## 10.7 Aux 1 (BROWN / WHITE Stripe) - Tachometer Drive

When all three ignition drives are being used for ignition purposes, Aux1 may only be used as a tachometer drive. In this case Aux1 should be wired like IG3 in tachometer mode.



Ensure that diode 'D3' has been replaced with a 680 Ohm resistor.

## 10.8 IG3 (BLUE / WHITE Stripe) - Shift Light

IG3 supplies power to turn on a high-intensity LED at the preset shift point. Wire the LED as shown in Figure 10.11. Note that a filament style bulb may not be connected to IG3 as it will draw too much current. The LED polarity must be correct or the LED will not function.

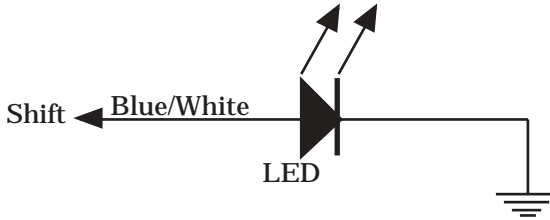

*Figure 10.11 Connection of an LED shift light to IG3*

## 10.9 IG3 (BLUE / WHITE Stripe) - Tachometer Drive

In this mode IG3 provides a 0 -12V pulse train to drive a low-level tachometer. There will be one output pulse for every ignition spark produced. Connect this wire directly to a low level tachometer. The LEM will NOT drive a high-level tachometer. These must be triggered from a coil's negative terminal or preferably modified to accept a low-level signal. Note that driving a high-level tachometer on a multi-coil engine presents some problems as each coil is not firing as often as a distributed engine's coil would.

## 10.10 Aux2 (GREEN / BLACK Stripe)

Aux2 is on the 4-pin connector only available on later models. Aux2 is very similar to Aux1 in RPM Switch configuration. Aux2 is normally used to supply a ground for a relay and may be switched on at a given RPM, MAP, TPS or injector duty cycle. Some high resistance (15W or higher) solenoids may be switched without using a relay.

