



# DisplayLink

## Installation and Setup Manual

Copyright 2009  
Link ElectroSystems Ltd



# Table of Contents

<b>Part I Introduction</b>	<b>4</b>
<b>Part II Installation</b>	<b>5</b>
1 Mounting .....	5
2 Electrical Connections.....	6
Wire-In ECU .....	6
Plug-In ECU .....	7
Older Generation ECUs .....	8
<b>Part III Basic Operation</b>	<b>9</b>
1 User Interface.....	9
2 First Time Setup.....	9
3 Display Configuration.....	11
4 Viewing Real Time Information.....	12
<b>Part IV Advanced Operation</b>	<b>13</b>
1 Customising Runtime Screens.....	13
2 Gauge Screens.....	15
3 Graphing Screens.....	16
4 Datalogging.....	17
Recording Logs .....	18
Log Playback .....	18
Deleting Logs .....	20
5 Alarms .....	21
Configuring Alarms .....	22
Example Application .....	24
6 Resetting the DisplayLink.....	24
<b>Part V ECU Parameters</b>	<b>25</b>

## 1 Introduction

Thank you for purchasing your DisplayLink. The DisplayLink is a fully graphical display and data logger for use with your Link Engine Management system.

The DisplayLink is compatible with most Link ECUs, including the new G4 range of advanced engine management systems. The DisplayLink provides a graphical means of displaying engine management information, and also adds on board data logging capabilities to your Link system (if it does not already have it).

The DisplayLink is designed to be easy to understand and operate, and take minimal time to set up. The DisplayLink was designed by automotive enthusiasts, for automotive enthusiasts. We hope you find it as exciting to use as we did to develop it.

## 2 Installation

The DisplayLink is housed in a rugged aluminum splash-proof enclosure, designed to withstand the harsh vehicle environment. Non-reflective glass has been used in order to reduce reflection and glare.

### CAUTION

It is essential that the DisplayLink is securely installed in a safe location and correctly wired. Sub-standard installation could result in harm to the DisplayLink or ultimately result in injury or harm to vehicle occupants and property.

### 2.1 Mounting

The most important step when installing the DisplayLink is choosing the mounting location. Use the following guidelines when choosing a location for the DisplayLink. Safety must be the first consideration at all times.

Mount the DisplayLink in a location that will not cause harm to vehicle occupants during normal use of the vehicle or in the event of an accident. Consult the vehicle owners manual for a suitable mounting location.

Do not install the DisplayLink in a location where it might impede the drivers vision.

Where cable length limits installation location, additional extension cables can be purchased from your nearest Link dealer. Do not cut or lengthen the supplied cables.

Four M5 threaded inserts are provided in the DisplayLink's rear plate to assist in installation. Use only the mounting screws provided to avoid any possible harm to the DisplayLink's internals. The diagram below shows the locations of the mounting screw inserts. Use this template as a guide when designing mounting brackets.

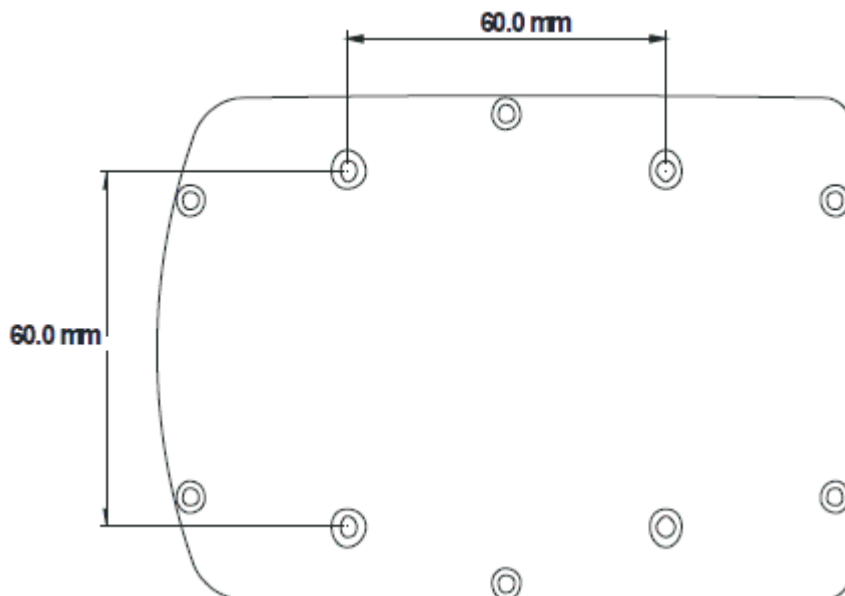

An alternate method of mounting is to use double sided tape to secure the DisplayLink to a flat panel. Ensure that high quality adhesive tape of at least 2mm thickness is used.

## 2.2 Electrical Connections

The DisplayLink is supplied with two cables exiting its enclosure. Note that each connector is of opposite gender. This cabling system utilises waterproof connectors and is designed to minimise installation effort and time. These cables are designed for high speed communications, so should not be modified in any way. Additional extension cables can be purchased from your nearest Link dealer if required.

Wiring installation is very simple requiring only connection of two power supply wires and a communications cable to the Link ECU. For any installation, the following connections must be made:

1. Ground (Black) – This wire must be well terminated to a clean point on the vehicles chassis. Do not be tempted to connect this wire to other ground wires.
2. +12V (Red) – Connect this wire to a switched 12V source. This wire should become live when the key is in the 'engine run' position. There is no point connecting this wire to a source that becomes live when the key is in the 'accessory' position as the DisplayLink can only communicate with the ECU when the ECU is powered (when key is in 'engine run' position). A 1 Amp in-line fuse must be fitted at the supply end of this wire.
3. Communications Cable – **The required communications cable will depend on the ECU type used , this should have been specified at the time of order. See wiring diagrams for required cable part numbers.**

When connecting power supply wires, ensure that good clean connections are made with other wiring and/or connectors. It is recommended that all joints be soldered and thoroughly insulated.

### WARNING

To avoid possible damage to the DisplayLink and your vehicles electrical system, it is recommended that the DisplayLink's power supply wires are connected to your vehicles electrical system by a trained auto electrician.

### 2.2.1 Wire-In ECU

The DisplayLink can be connected to the latest generation Link G4 Wire-In ECUs. The following diagram shows the typical connections required for operation.

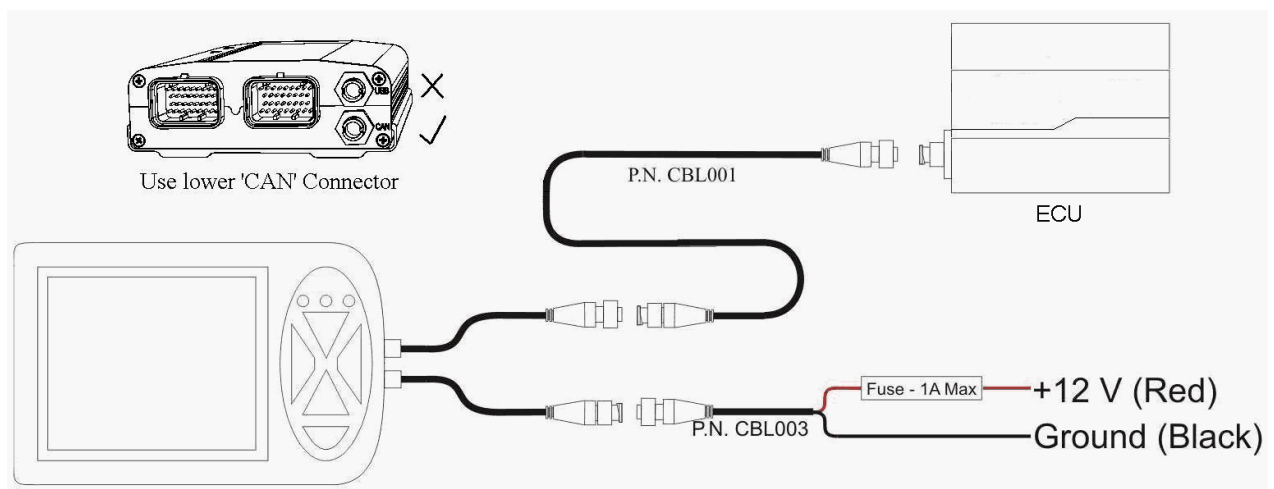

## 2.2.2 Plug-In ECU

The DisplayLink can be connected to the latest generation Link G4 Plug-In ECUs. The following diagram shows the typical connections required for operation.

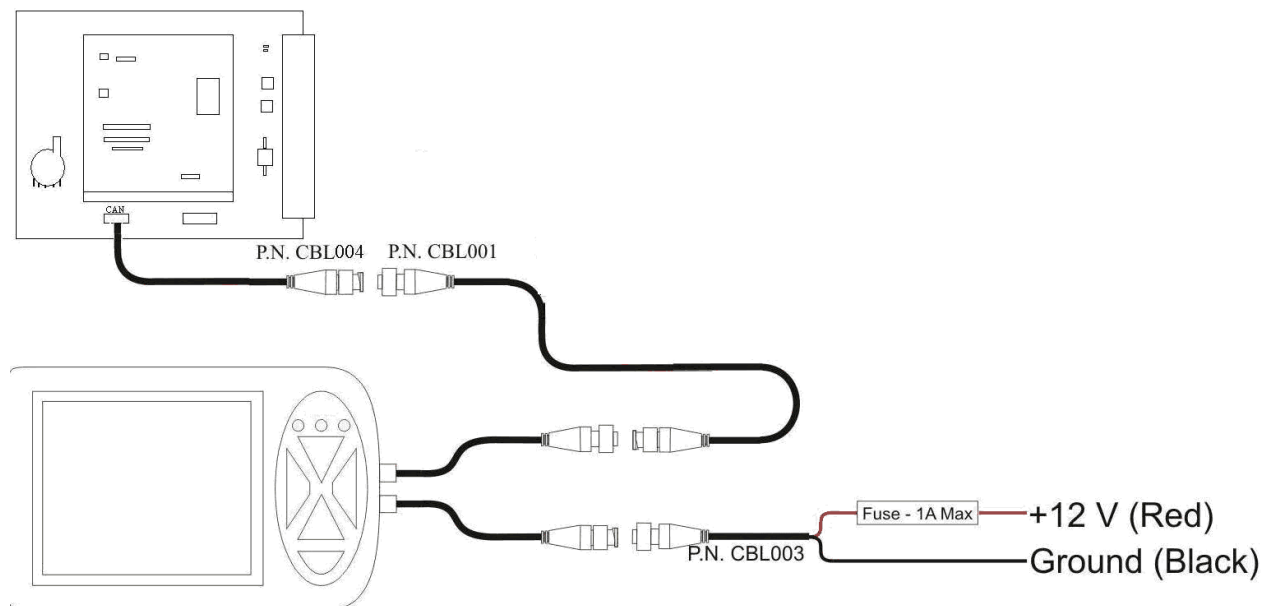

There is a risk of causing electro-static damage to your Link Plug-In ECU. It is highly recommended that you take your ECU to a Link dealer to have the DisplayLink cable installed.

### WARNING

When installing the DisplayLink with a Plug-In ECU, it is necessary to remove the ECU from the vehicle and remove the ECU from its enclosure. The following static precautions must be observed when installing the DisplayLink communications cable:

1. Do NOT remove the covers from the ECU until it has been completely removed from the vehicle.
2. Do NOT touch the exposed pins in the ECU header.
3. Only work on the ECU on a clean conductive work surface such as a steel bench top.
4. Wear a conductive wrist strap connected to the conductive work surface. These are essential and are available from local electronics hobby shops or supplied with your Plug-In ECU.
5. Do NOT unnecessarily touch other parts inside the Link ECU.

To install the communications cable (CBL004):

1. Remove the Link ECU from the vehicle.
2. Following the above static precautions, remove the ECU circuit board from its enclosure.
3. Plug the DisplayLink communication cable into the communications connector labeled 'CAN/RS232'.
4. Fit cable ties through the holes if present in the circuit board and tighten to secure the cable. Otherwise cables should be secured to the header or case to prevent direct strain on the PCB.
5. Cut a slot in the ECU enclosure for the cable to exit.
6. Reassemble the ECU and refit to the vehicle.

### 2.2.3 Older Generation ECUs

The DisplayLink can also be connected to previous generation Link non-G4 Wire-In ECUs. The following diagram shows the typical connections required for operation.

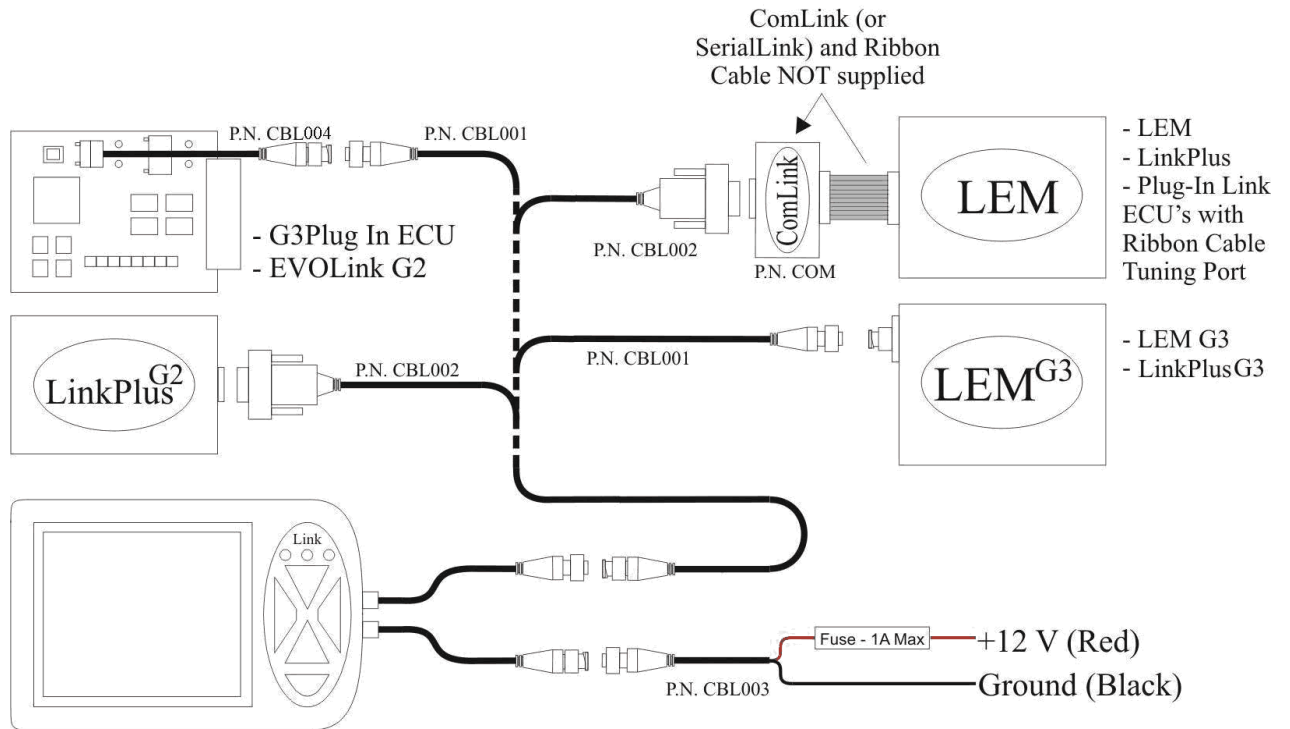

## 3 Basic Operation

The DisplayLink uses a back-lit high contrast graphical Liquid Crystal Display (LCD) that when combined with advanced software provides a full engine management system display and data logging solution. The graphical LCD allows multiple screens of information to be displayed in the most appropriate format for the user. The DisplayLink is packaged in an attractive water resistant aluminium enclosure designed to be installed on the dashboard of most vehicles.

### 3.1 User Interface

The user interface to the DisplayLink consists of five navigation buttons, the graphical LCD display and three warning lamps (LED's). The following diagram shows the location of the DisplayLink's user interface components.

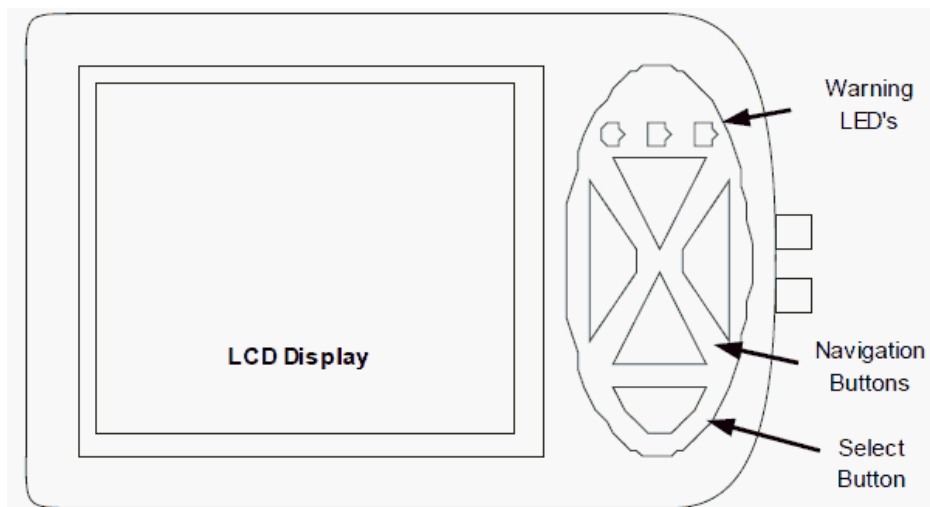

Navigation buttons are used to select between menu options and DisplayLink screens. The warning LED's are used to supplement the on screen warnings alarm warnings.

The DisplayLink uses a simple format for accessing menus:

- Press the UP or DOWN navigation buttons to move up or down through the lists of menu items.
- Press the SELECT button to select a particular menu item. Depending on the particular menu item, pressing SELECT will either open another menu or set the item to adjust mode. A menu item will flash if it is in adjust mode.
- A menu item in adjust mode (flashing) can be changed by using the LEFT and RIGHT (or UP and DOWN) navigation buttons.
- Pressing SELECT on a menu item in adjust mode will store its setting permanently. The item will stop flashing once the setting has been stored.

### 3.2 First Time Setup

First time setup of the DisplayLink is remarkably easy. All that is required is that the DisplayLink is told what type of Link ECU it is connected to. This procedure involves navigating through the DisplayLink's setup menu's and is a good chance to get used to using these menu's.

To set the ECU type, the DisplayLink and Link ECU must be correctly installed. To set ECU type perform the following procedure:

Turn the ignition key ON and ensure that both the DisplayLink and Link ECU are powered up

(Hint: listen for the short cycle of the fuel pump to confirm the ECU has power).

1. Use the LEFT and RIGHT navigation buttons to locate the Setup screen (shown below).
2. Press the SELECT button to invoke the main setup menu.

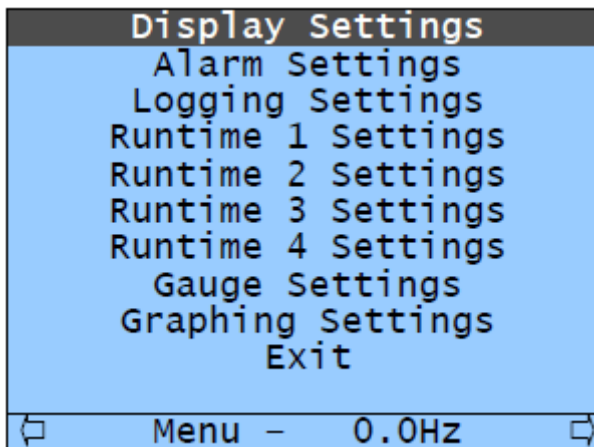

3. Use the UP and DOWN navigation buttons to highlight the 'Display Settings' menu item.
4. Press the SELECT button to open the Display Settings menu (as shown on next page).
5. Use the UP and DOWN navigation buttons to highlight the 'ECU Type' menu item.

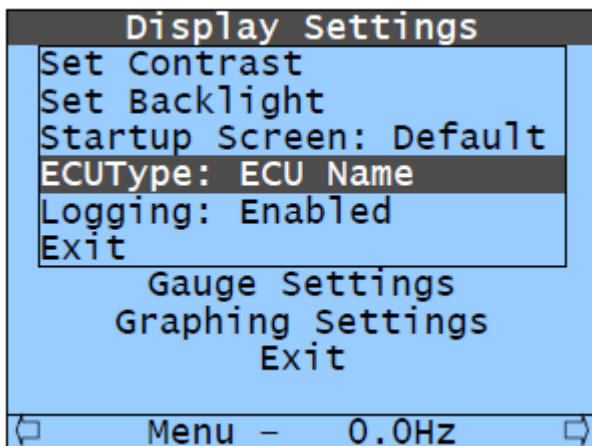

6. Press the SELECT button to set 'ECU Type' to adjust mode. ECU Type will start flashing to indicate that it can be changed.
7. Use the UP and DOWN navigation buttons to find your particular ECU type.
8. Press the SELECT button to store the selected ECU type. ECU type should stop flashing.
9. Use the UP and DOWN navigation buttons to highlight 'Exit'.
10. Press SELECT to exit the Display Settings menu.
11. Use the UP and DOWN navigation buttons to again highlight 'Exit'.
12. Press SELECT to exit the main setup menu.

You can now use the LEFT and RIGHT navigation buttons to cycle through the various display screens. If the installation is complete and the correct ECU type is selected, then accurate information from the Link ECU should be displayed on each screen. The green LED should illuminate to indicate that the DisplayLink is communicating with the ECU.

### 3.3 Display Configuration

The 'Menu' screen allows access to the main setup menu as shown on the following page. To access the main setup menu, press the LEFT or RIGHT navigation button until the Setup Screen is visible, then press the SELECT button. The main setup menu looks like this:

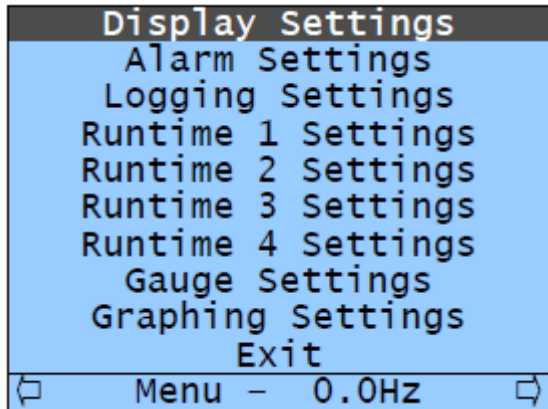

The DisplayLink uses a simple format for accessing menus:

- Press the UP or DOWN navigation buttons to move up or down through the lists of menu items.
- Press the SELECT button to select a particular menu item. Depending on the particular menu item, pressing SELECT will either open another menu or set the item to adjust mode. A menu item will flash if it is in adjust mode.
- A menu item in adjust mode (flashing) can be changed by using the LEFT and RIGHT (or UP and DOWN) navigation buttons.
- Pressing SELECT on a menu item in adjust mode will store its setting permanently. The item will stop flashing once the setting has been stored.

Menu Items are arranged under the following headings:

#### Display Settings

##### Set Contrast

Adjusts display contrast.

##### Set Backlight

Adjusts display back lighting brightness.

##### Startup Screen

Sets the graphics that is displayed when the DisplayLink first powers up.

##### ECU Type

Sets the Link ECU that the DisplayLink is connected to.

##### Logging: Enabled

Enables or disables logging functions.

#### Alarm Settings

Setup custom high and low priority warning alarms.

#### Logging Settings

**Playback**

Enables or disables playback of stored data logs.

**Used Memory %**

Shows the % of logging memory that has been used.

**Delete All Logs**

Deletes ALL stored data logs.

**No Download Available**

Downloading stored logs to a PC is not currently available.

**Log Format**

Selects the log format for PC downloads.

**Runtime # Settings**

Configures the corresponding Runtime screen.

**Gauge Settings**

Configures customisable values on the Gauge screens.

**Graphing Settings**

Configures axis and update rate for the Graphing screen.

### **3.4 Viewing Real Time Information**

Once initial setup is complete and the DisplayLink is connected to the ECU, real time data can be displayed.

To access this data, the LEFT and RIGHT navigation keys can be pressed to cycle between the menu and different real time data screens.

## 4 Advanced Operation

The following sections described use of the DisplayLink's more advanced features such as Data Logging, Graphing, Alarms and customising the DisplayLink.

### 4.1 Customising Runtime Screens

Runtime Screens are the four screens containing numerical information. Each screen can contain up to eight different display values. Each screen can be individually customised to the users requirements. The currently selected Runtime Screen is shown in the title bar at the bottom of the display area. Runtime Screens are labeled 'Runtime 1', 'Runtime 2', 'Runtime 3' and 'Runtime 4'. The following example shows how to change the values displayed on a Runtime Screen. The diagram below shows a typical Runtime Screen. Note that the title bar shows that this is the 'Runtime 1' screen. Also note that even though this Runtime Screen can display up to eight values, currently only six are being displayed.

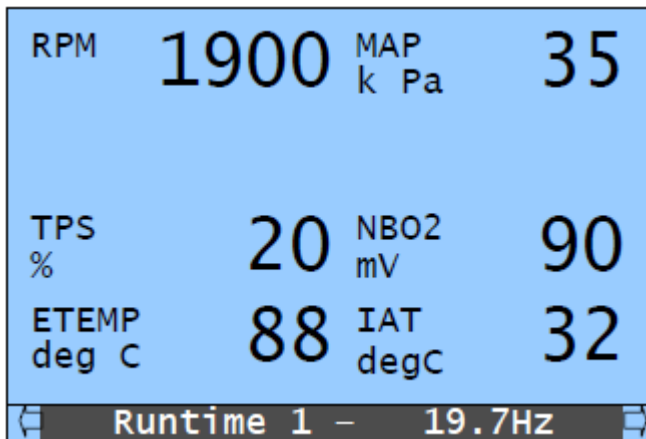

1. Use the LEFT and RIGHT navigation buttons to locate the Menu screen.
2. Press the SELECT button to invoke the main setup menu.
3. Use the UP and DOWN navigation buttons to highlight the 'Runtime 1 Settings' menu item as shown following.

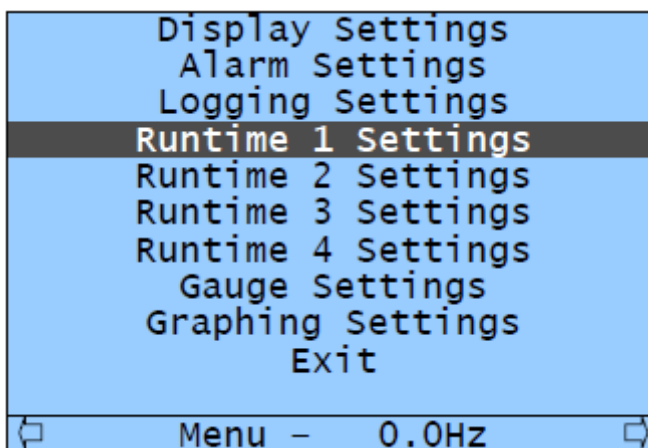

4. Press the SELECT button to open the Runtime Settings menu.
5. Use the UP and DOWN navigation buttons to highlight the fourth item down. Note that the items are displayed on the Runtime screen in the order: 1 (top left), 2 (top right), 3 (second line left), 4 (second line right) etc ...

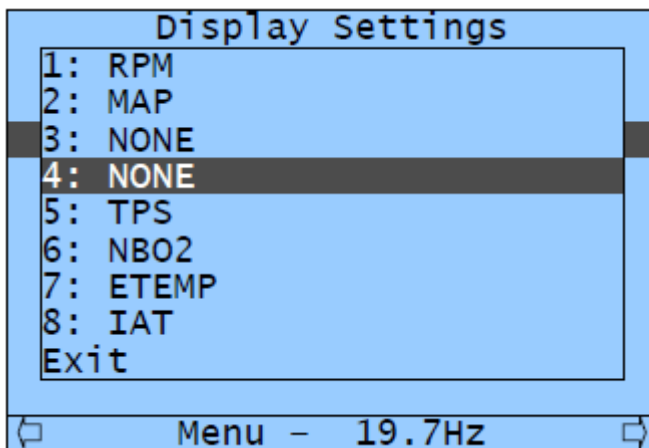

6. Press the SELECT button to set Item 4 to adjust mode. Item 4 will start flashing to indicate that it can be changed.

7. Press the UP and DOWN navigation buttons to find the parameter to be displayed (e.g. INJ DC). Note that selecting 'NONE' results in nothing being displayed in that location.

8. Press the SELECT button to store the selected parameter, Item 4 should stop flashing. Injector Duty Cycle is now selected for display (as shown below).

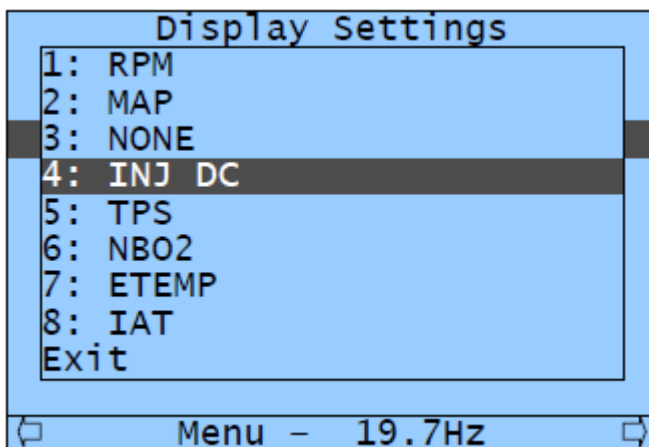

9. Use the UP and DOWN navigation buttons to highlight 'Exit'.

10. Press SELECT to exit the Runtime Settings menu.

11. Use the UP and DOWN navigation buttons to again highlight 'Exit'.

12. Press SELECT to exit the main setup menu. After performing this procedure, the customised Runtime screen appears as below

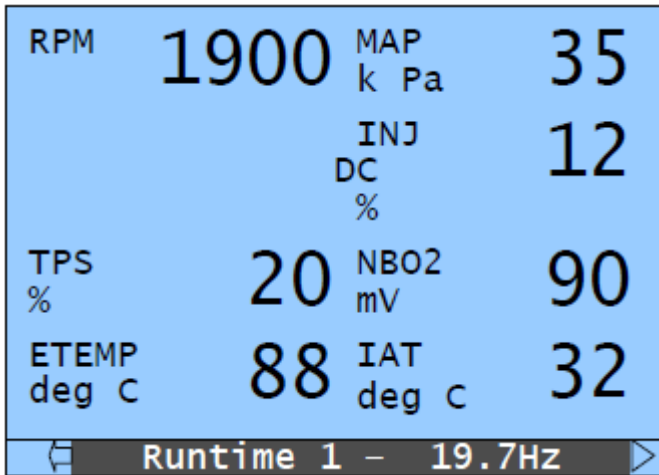

The different parameters that can be displayed will depend on the type of Link ECU connected. Later version ECU's such as the G4 range will have many more available parameters than early ECU's. A list of abbreviations for the parameters and the ECU's that support them is given in the ECU Parameters section.

## 4.2 Gauge Screens

The DisplayLink's four Gauge Screens allow viewing of pre-defined ECU parameters in a graphical manner. Gauge screens provide alternative ways of visualising the ECU runtime values. A gauge best displays rapidly changing data such as RPM or MAP so it may be evaluated at a glance.

Gauges can not be customised. But the additional parameters found on Gauge screens 2, 3, and 4, can be modified in the same manner as runtime values using the Gauge Settings selection in the Menu.

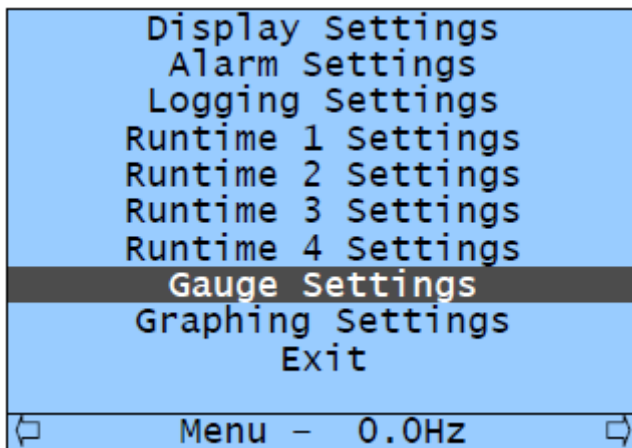

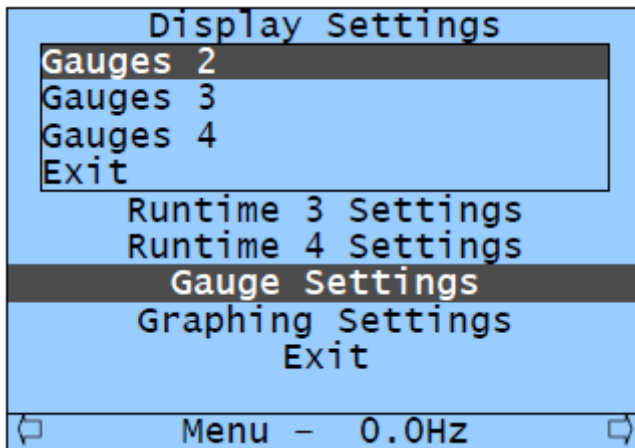

### 4.3 Graphing Screens

The Graphing Screen allows an ECU parameter to be plotted against time, or two parameters to be plotted against each other (e.g. Boost vs. RPM). Customising the Graphing Screen is performed by altering settings in the 'Graphing Settings' menu on the main setup screen. The following procedure describes how to customise the Graphing Screen:

1. Use the LEFT and RIGHT navigation buttons to locate the Setup screen.
2. Press the SELECT button to invoke the main setup menu.
3. Use the UP and DOWN navigation buttons to highlight the 'Graphing Settings' menu item (as shown following).

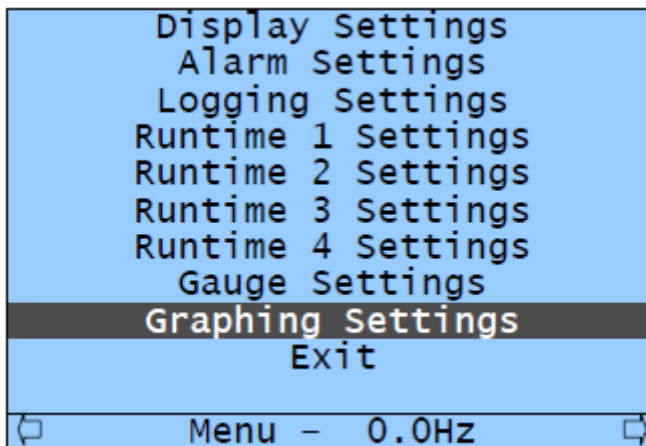

4. Press the SELECT button to open the Graphing Settings menu as shown following.

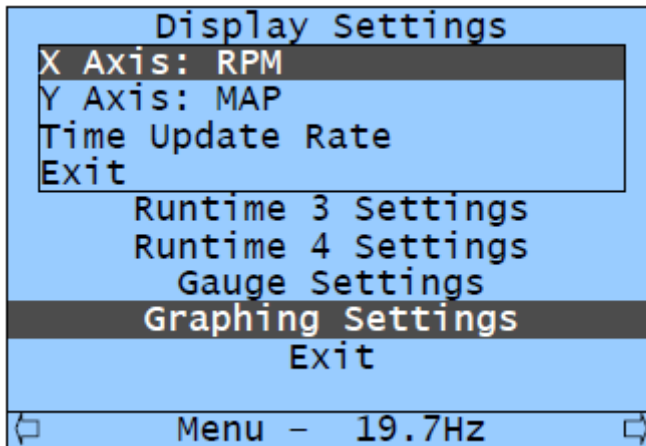

5. Use the UP and DOWN navigation buttons to highlight 'X Axis:'.
6. Press the SELECT button to set 'X Axis:' to adjust mode. 'X Axis' will start flashing to indicate that it can be changed.
7. Use the UP and DOWN navigation buttons to find the parameter to be scaled on the X Axis (horizontal). Note that 'Time' will only work correctly on the X Axis.
8. Press the SELECT button to store the selected parameter. 'X Axis:' should stop flashing and will display the selected parameter.
9. Use the UP and DOWN navigation buttons to highlight 'Y Axis:'.
10. Perform the same procedure described in steps 6 to 8 to set the parameter that will be scaled on the Y Axis (vertical).
11. If 'X Axis:' is set to 'Time', the rate at which the graphing screen scrolls can be adjusted. To do this, use the UP and DOWN navigation buttons to highlight 'Time Update Rate'.
12. Press the SELECT button to set 'Time Update Rate' to adjust mode. 'Time Update Rate' will start flashing to indicate that it can be changed.
13. Use the UP and DOWN navigation buttons to adjust the rate at which the screen scrolls. This number indicates the time between updates, so a lower number will result in faster scrolling.
14. Use the UP and DOWN navigation buttons to highlight 'Exit'.
15. Press SELECT to exit the Graphing Settings menu.
16. Use the UP and DOWN navigation buttons to again highlight 'Exit'.
17. Press SELECT to exit the main setup menu.

Graphing may be paused by pressing the SELECT button while viewing the Graphing Screen. Pressing the SELECT button again will clear the graphing screen and restart plotting.

## 4.4 Datalogging

One very powerful feature of the DisplayLink is its ability to log Link ECU runtime parameters. On board storage allows the DisplayLink to record up to approximately 30 minutes of logging time. Stored logs can be played back at a later stage for analysis. All of the runtime values available from the Link ECU are logged.

### 4.4.1 Recording Logs

To record a log, press and hold the SELECT button while viewing any screen except the Setup Screen. The DisplayLink will then enter logging mode. Logging mode is indicated in the title bar at the bottom of the screen as shown on the following page.

The DisplayLink will then create a new log and begin saving data to it.

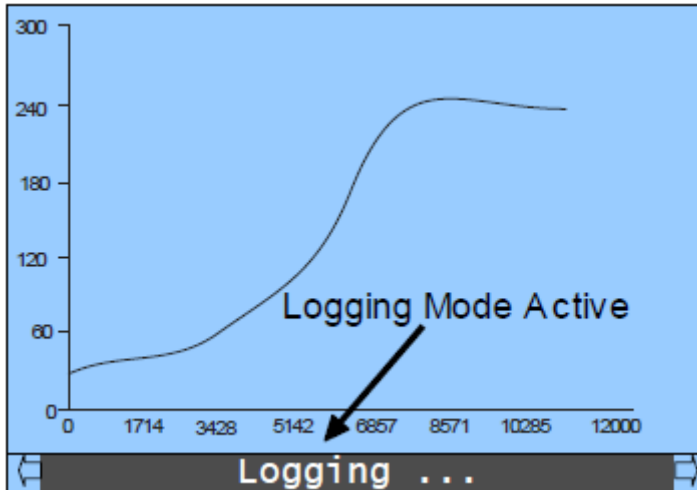

### 4.4.2 Log Playback

To playback stored logs, the DisplayLink's Playback mode must be activated. In Playback mode the DisplayLink functions similarly to when displaying runtime data from a Link ECU except that the displayed data is from the stored log.

*The information displayed on each screen in Playback mode is that from the stored log, not what is currently being sent from the Link ECU.*

To put the DisplayLink in Playback mode, at least one log must have been recorded.

To select a log for playback, perform the following procedure:

1. Use the LEFT and RIGHT navigation buttons to locate the Setup screen.
2. Press the SELECT button to invoke the main setup menu.
3. Use the UP and DOWN navigation buttons to highlight the 'Logging Settings' menu item as shown

following.

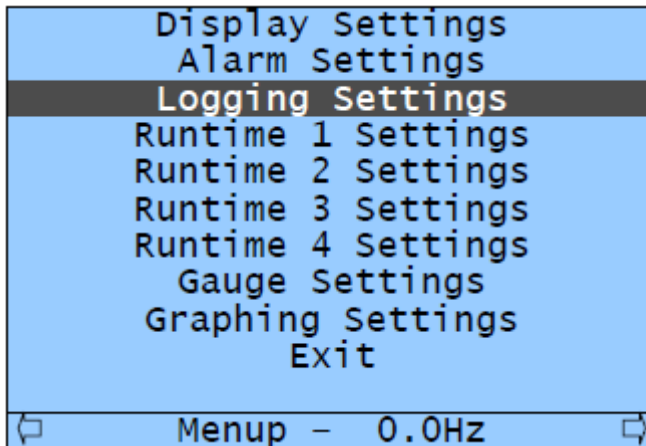

4. Press the SELECT button to open the Logging Settings menu (as shown following).
5. Use the UP and DOWN navigation buttons to highlight the log you wish to play back.

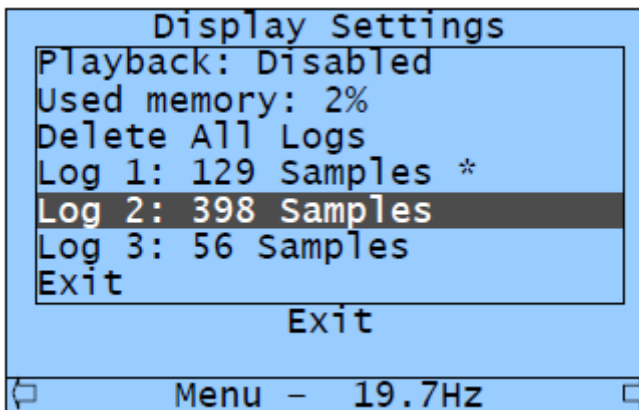

6. Press the SELECT button to set the log as the playback log. The asterisk symbol should now be displayed at the end of the name of the log that is to be played back.
7. Use the UP and DOWN navigation buttons to highlight 'Playback:'.
8. Press SELECT to activate playback. The 'Playback' menu item will now show playback as 'Active' (as shown following).

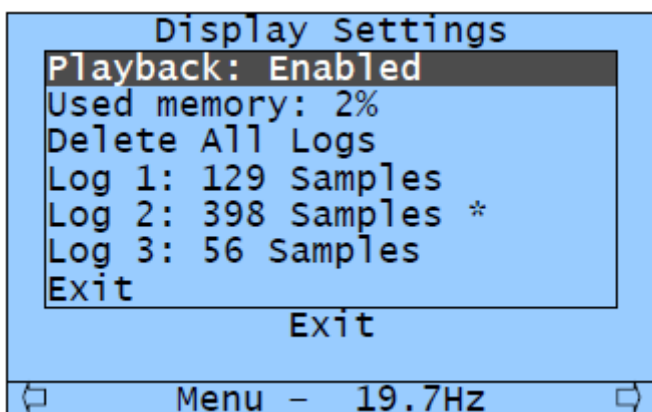

9. Use the UP and DOWN navigation buttons to highlight 'Exit'.
10. Press SELECT to exit the Graphing Settings menu.
11. Use the UP and DOWN navigation buttons to again highlight 'Exit'.

12. Press SELECT to exit the main setup menu.

The DisplayLink can now be operated as normal but displayed data will be from the selected log rather than the Link ECU. Playback mode is indicated in the title bar as shown following.

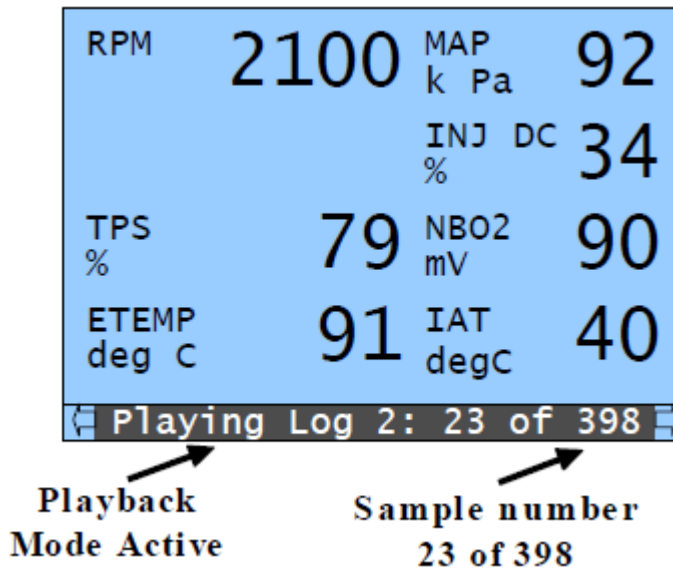

#### 4.4.3 Deleting Logs

Playback mode can be paused and resumed at any stage by pressing the SELECT button on any screen except the Setup Screen.

In order to free up memory, all logs may be deleted by selecting 'Delete All Logs' from the Logging Settings menu as follows:

1. Use the LEFT and RIGHT navigation buttons to locate the Setup Screen.
2. Press the SELECT button to invoke the main setup menu.
3. Use the UP and DOWN navigation buttons to highlight the 'Logging Settings' menu item.
4. Press the SELECT button to open the Logging Settings menu as shown on the following page..
5. Use the UP and DOWN navigation buttons to highlight 'Delete All Logs'.
6. Press the SELECT button to delete all logs. This will delete ALL stored logs, you will NOT be prompted 'Are you sure'. Stored log files will disappear from the menu.

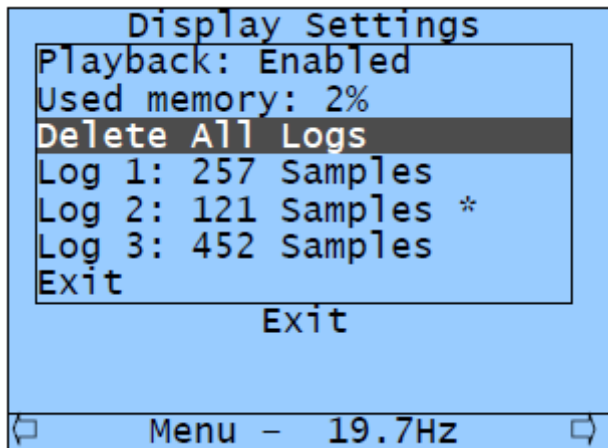

7. Use the UP and DOWN navigation buttons to highlight 'Exit'.
8. Press SELECT to exit the Graphing Settings menu.
9. Use the UP and DOWN navigation buttons to again highlight 'Exit'.
10. Press SELECT to exit the main setup menu.

## 4.5 Alarms

The DisplayLink incorporates a configurable Alarm Warning system. The following list summarises the features offered by the DisplayLink's warning alarm system:

- Up to eight configurable warning alarms.
- Each alarm can be assigned high or low priority.
- Alarms are based on “greater than” or “less than” conditions.
- Alarms can be combined to make conditional on multiple parameters.

Low Priority alarms cause the title bar at the bottom of the screen to flash and the orange warning LED to illuminate. Low priority alarms will stop when the condition that caused them no longer exists.

High Priority alarms cause the entire screen to flash a large warning message and the red warning LED to illuminate. High priority alarms must be acknowledged by pressing any button. The title bar will continue to flash after the alarm has been acknowledged until the condition that caused the alarm no longer exists. The following picture shows an example high priority alarm indicating that the engine speed has exceeded a particular value.

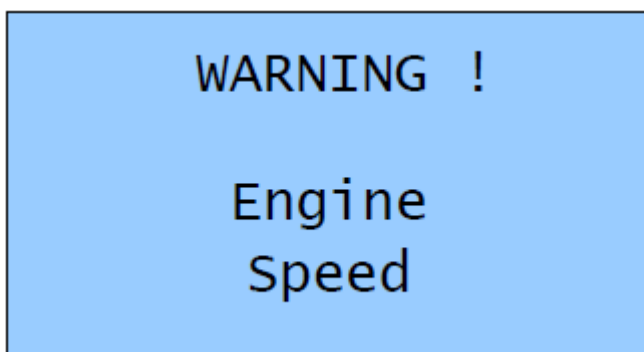

### 4.5.1 Configuring Alarms

Setting up alarms is performed using the Alarms Settings menu (found in the main setup menu). The following procedure describes how to configure alarms:

1. Use the LEFT and RIGHT navigation buttons to locate the Setup screen.
2. Press the SELECT button to invoke the main setup menu.
3. Use the UP and DOWN navigation buttons to highlight the 'Alarm Settings' menu.

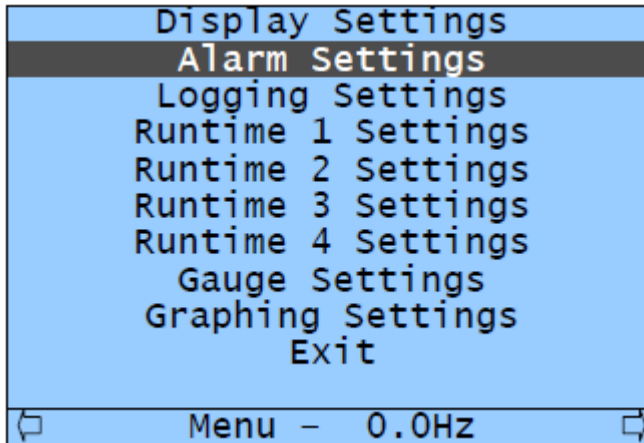

4. Press the SELECT button to open the alarm settings menu as shown below.
5. Select the alarm to be configured. Press the UP and DOWN, LEFT and RIGHT navigation buttons to select the alarm that is to be configured. Note that each row represents one alarm. Place the highlighted block in the leftmost column.
6. Select the parameter for the alarm. Press SELECT, then use the UP and DOWN navigation buttons to set the parameter that the alarm will be based on. The highlighted area will start flashing to indicate that the value can be adjusted. Refer to Appendix A for a list of parameters. Press SELECT to confirm the parameter. The highlighted area will stop flashing.

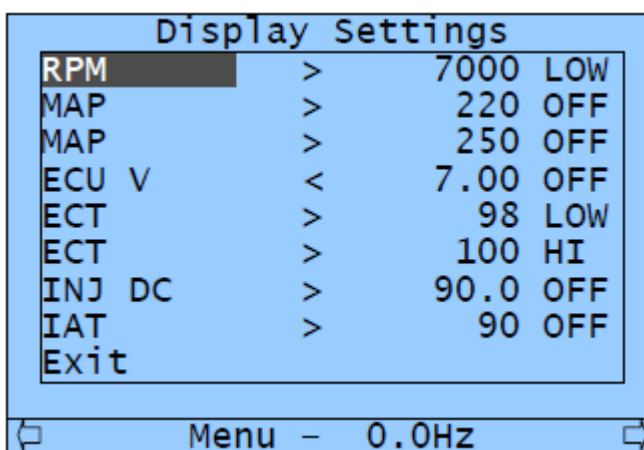

Select Greater Than or Less Than. Use the RIGHT button to move to the second to left column (contains < or > symbols). Press the SELECT button to change the greater than or less than option. The highlighted area will begin to flash to indicate that it can be changed. Use the UP and DOWN buttons to select < or >, then press SELECT to confirm.

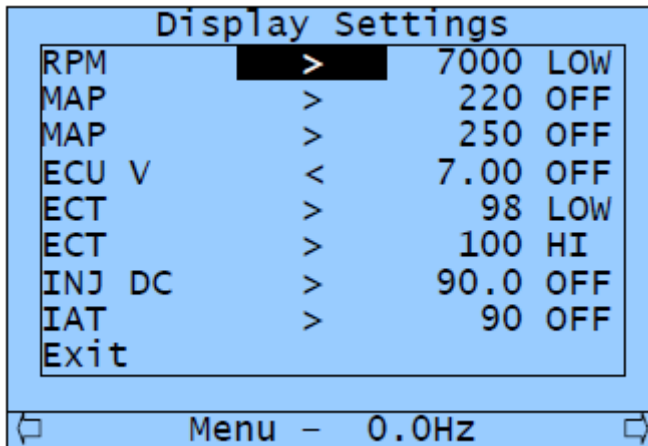

- Select < (Less Than) if you want the alarm to be activated when the selected parameter is less than a certain value.

- Select > (Greater Than) if you want the alarm to be activated when the selected parameter is greater than a certain value.

8. Select the Value. Use the RIGHT button to move to the second to right column (contains numbers). Press the SELECT button to change the alarm value. The highlighted area will start flashing to indicate that the value can be changed. This is the value that the alarm must be greater than or less than to be activated. Use the UP and DOWN buttons to change the value then press the SELECT button to confirm changes.

9. Select the Alarm Type. Use the RIGHT button to move to the rightmost column. Press the SELECT button to change the alarm type. The highlighted area will start flashing to indicate that the alarm type can be changed. Use the UP and DOWN buttons to select the desired alarm type then press SELECT to confirm changes.

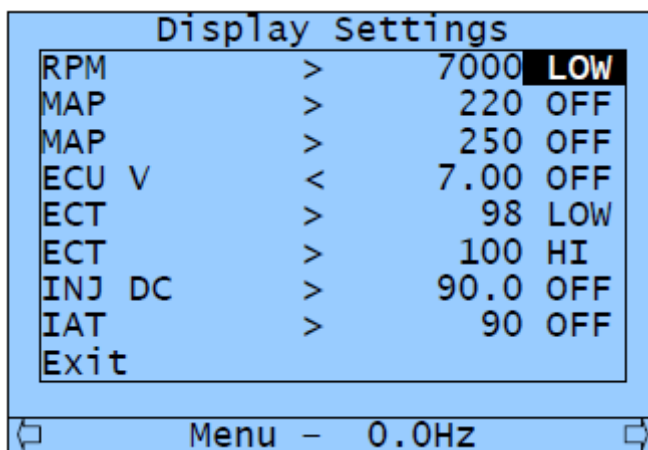

- Select OFF to disable the alarm.

- Select LOW to set the alarm as a Low Priority Alarm.

- Select HI to set the alarm as a High Priority Alarm.

- Select AND to combine the alarm condition with the condition of the alarm on the following line.

10. Use the UP and DOWN navigation buttons to highlight 'Exit'.

11. Press SELECT to exit the Graphing Settings menu.

12. Use the UP and DOWN navigation buttons to again highlight 'Exit'.

13. Press SELECT to exit the main setup menu.

#### 4.5.2 Example Application

A low priority alarm can be used as a shift light. The following example shows the second alarm configured as a shift light that will activate if the engine speed goes above 7500 RPM.

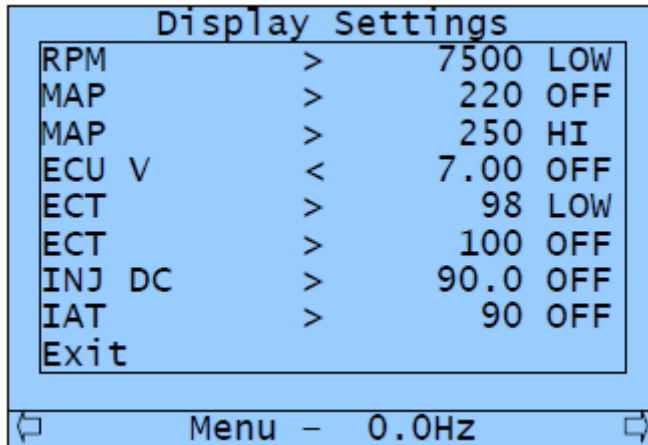

Display Settings			
RPM	>	7500	LOW
MAP	>	220	OFF
MAP	>	250	HI
ECU V	<	7.00	OFF
ECT	>	98	LOW
ECT	>	100	OFF
INJ DC	>	90.0	OFF
IAT	>	90	OFF
Exit			

Menu - 0.0Hz

Note that the above example also shows the first alarm configured to generate a low priority warning if engine temperature is above 98 degrees. It also shows the third alarm configured to generate a high priority warning if MAP exceeds 250 kPa.

#### 4.6 Resetting the DisplayLink

The DisplayLink can be reset to the factory default settings by holding down the select button while the DisplayLink is powered up. This will clear all custom configurations and delete all stored logs.

## 5 ECU Parameters

The following table details the parameters that are available from various Link ECUs for display and logging.

Code	Description	Units
TIME	Time	seconds
ON BD T	Display Temperature	deg
RPM	Engine Speed	rpm
MAP	Manifold Absolute Pressure	kPa
TPS	Throttle Position	%
WG DC	Wastegate Duty Cycle	%
IDLE DC	Idle Duty Cycle	%
NBO2	Narrowband O2	v(Volts)
WBO2 1	Wideband O2 #1 Air/Fuel Ratio	AFR
WBO2 2	Wideband O2 #2 Air/Fuel Ratio	AFR
KNK 1	Knock Sensor 1 Level	
KNK 2	Knock Sensor 2 Level	
KNK CNT	Knock Count	
KNK THR	Knock Threshold	
ECT	Engine Coolant Temperature	°C
IAT	Intake Air Temperature	°C
AAT	Ambient Air Temperature	°C
W SPD	Driven Wheel Speed	km/h
G SPD	Ground Speed	km/h
Z FUEL	Zone Fuel	
INJ DC	Injector Duty Cycle	%
PW	Injector Pulse Width	ms
Z IGN	Zone Ignition	
IGN	Ignition Angle	deg
ECU V	ECU Voltage	v(Volts)
ECU T	ECU Temperature	deg
INJ TM	Injector Timing	deg
INJS DC	Staged (secondary) Injector Duty Cycle	%
I CAM L	Inlet Cam Position L	°A
I CAM R	Inlet Cam Position R	°A
E CAM L	Exhaust Cam Position L	°R
E CAM R	Exhaust Cam Position R	°R
MGP	Manifold Gauge Pressure	kPa
BARO	Barometric Pressure	kPa
F RPM	RPM Limit	
F MAP	MAP Limit	
F IAT	IAT Limit	

Code	Description	Units
F AC	AirCon Request	
F FAN	Radiator Fan	
F DRV1	Drive 1	
F DRV2	Drive 2	
F THRT	Throttle	
F KNK	Knock Sys	
F AL	AntiLag	
F LNCH	Launch Control	
F FS	Flatshift	
PYRO 1 to 4	Exhaust Pyro 1 to 4	deg
FREQ 1 to 6	DI Frequency 1 to 6	Hz
SPD 1 to 6	DI Speed 1 to 6	kmh
MAF	Mass Air Flow Voltage	v(Volts)
TEMP 1 to 4	An Temp 1 to 4	°C
PRESS 1 to 6	GP Pressure 1 to 6	kPa
AN V1 to V11	An Volt 1 to V11	v(Volts)
FUEL T	Fuel Temperature	°C
GEAR	Gear Position	
MAF	Mass Air Flow	g/s
DWELL	Dwell Time	ms
T1 ERR	Trig 1 Error Count	
T2 ERR	Trig 2 Error Count	
RPM LIM	RPM Limit	
MAP LIM	MAP Limit	
SPD LIM	Speed Limit	
MAX IGN	Max Ignition	
VOL LIM	Volt Limit	
O F CUT	Overrun Cut	
LOW VOL	Low Volt	
LAU LIM	Launch RPM Limit	
WAKEUP	Wakeup	
AN LIM	Analog Limit	
TRIG 1	Trig 1 Signal	
TRIG 2	Trig 2 Signal	