

# EVOLink<sup>G3</sup>

## Engine Management

Plug-in sequential fuel and ignition control

# EVOLink EVO I - IX Installation Manual

Board V1.3 02-05-07

## Link ElectroSystems Ltd. Warranty Statement

Effective 5pm, April 5<sup>th</sup>, 1992

All products manufactured or distributed by Link ElectroSystems Ltd. Are subject to the following, and only the following, **LIMITED EXPRESS WARRANTIES, and no others**

For a period of one (1) year from and after the date of purchase of a new Link ElectroSystems Ltd. Product, Link ElectroSystems Ltd. Warranties and guarantees only to the original purchaser / user that such a product shall be free from defects of materials and workmanship in the manufacturing process. A product claimed to be defective must be returned to the place of purchase. Link ElectroSystems Ltd., at its sole option, shall replace the defective product with a comparable new product or repair the defective product. This expressive warranty shall be inapplicable to any product not properly installed and properly used by the purchaser – user or to any product damaged or impaired by external forces. This is to the extent of warranties available on this product. Link ElectroSystems Ltd. Shall have no liability whatsoever for consequential damages following from the use of any defective product or by reason of the failure of any product. Link ElectroSystems Ltd. Specifically disclaims and disavows all other warranties, express or implied including, without limitation, all warranties of fitness for a particular purpose (except for those which apply to product or part thereof that is used or bought for use primarily for personal, family or household purposes), warranties of description, warranties of merchantability, trade usage or warranties of trade usage.

## Link ElectroSystems Ltd. License Agreement

The programme in this system is licensed not sold. Link ElectroSystems Ltd. Grants you a license for the programme only in the country where you acquired the programme. You obtain no rights other than those granted under this license. Under this license you may use the programme on only one machine at a time. If you transfer the programme you must transfer a copy of this license and all other documentation. Your license is then terminated. You may terminate your license at any time. Link ElectroSystems Ltd. May terminate your license if you fail to comply with the terms and conditions of this license. In either event you must destroy your copy of the programme

# By Link ElectroSystems Ltd.

© Link ElectroSystems Ltd. 2007

# CONTENTS

1	Introduction.....	3
1.1	Link G3 ECU's.....	3
1.2	LINK SUPPORT.....	4
1.3	SAFETY FIRST.....	5
2	Installation.....	6
2.1	ECU Installation.....	6
2.2	Pre Installation Configuration.....	8
2.3	Installation Procedure (EVO I - III):.....	9
2.4	Special Installation Instructions for EVO III.....	10
2.5	Installation Procedure (EVO IV – VIII):.....	11
2.6	Installation Procedure (EVO IX):.....	11
2.7	Map Sensor Installation.....	12
2.8	Intake Air Temp Sensor Installation.....	14
3	First Time Setup.....	16
3.1	CONNECTING TO PCLINK.....	16
3.2	INITIAL ADJUSTMENTS.....	19
	BASE CONFIGURATION.....	19
	MAP SENSOR CALIBRATION.....	19
	TPS CALIBRATION.....	20
	IAT SENSOR SELECTION.....	21

# 1 INTRODUCTION

Thank you for purchasing your Link ElectroSystems Ltd. Plug-In Engine Control Unit (ECU). Link G3 ECU's are an advanced, fully programmable microprocessor controlled Engine Management System. The EVOLink<sup>G3</sup> is the third generation of the successful range of EVOLink ECU's now based on the new G3 software/hardware platform.

All Link Plug-In Engine Management Systems are designed with minimum installation in mind. Where practical, Link Plug-In systems replace the circuit board inside the factory ECU enclosure. This provides an unobtrusive means of fitting a fully programmable engine management system to your vehicle without any permanent modifications and a completely invisible install.

Link Engine Management Systems are designed with the final result in mind. Not only do they boast an impressive range of performance features, but are designed with a focus on safety, reliability and driveability. However, the ultimate success of your engine management upgrade is determined by how well the system is installed and tuned.

## 1.1 Link G3 ECU's

G3 ECU's are the third generation of Link ElectroSystems proven Engine Management Systems. What makes G3 ECU's unique is a new hardware design based around one of the most powerful microprocessors used in after-market engine management. Hardware is designed using the latest technologies for ultimate performance, reliability and electromagnetic interference compliance.

A new software architecture has also been developed to optimise the potential of this processor. This G3 software platform boasts an impressive list of features giving new levels of user adjustments. This flexibility allows the tuner to have complete control over the engine management system.

G3 software employs high resolution fuel and ignition tables with configurable load and RPM centers. When coupled with four dimensional fuel and ignition mapping, barometric pressure compensation and intake air temperature correction this gives an unprecedented level of tuning accuracy.

Included in the G3's impressive feature set are full variable valve timing (VVT) control and advanced motorsport features. All G3 ECU's are in field upgradeable, there is no need to return the unit for software updates as new features are released.

## 1.2 LINK SUPPORT

Link ElectroSystems Ltd. appreciates your custom and has full confidence that you will be satisfied with your engine management system upgrade. Should any issue arise or for technical assistance the following support options are available:

- Contact your nearest Link Dealer (a dealer list is available on our website).
- Link ElectroSystems Website – [www.linkecu.com](http://www.linkecu.com)
- Technical Support Email – [tech@linkecu.com](mailto:tech@linkecu.com)
- On line Discussion – [www.linkecu.com/forums](http://www.linkecu.com/forums)

## 1.3 SAFETY FIRST

Your Link Plug-In ECU is designed to enhance the performance of your vehicle. However in all cases, your vehicle must be operated in a safe manner. Do not tune your vehicle while operating it on public roads. Obey road rules at all times.



Failure to follow all installation and operating instructions may result in damage to the Link ECU, personal injury, or harm to property.

## 2 INSTALLATION

The following sections describe physical installation of the EVOLink<sup>G3</sup> ECU and required sensors. It is recommended that your Link ECU is installed and tuned by a professional. This will ensure you get the most out of your Link ECU minimise the possibility of damage to the ECU or vehicle. The EVOLink<sup>G3</sup> is sophisticated high end ECU and requires significant knowledge of engine management to install and tune.

### 2.1 ECU Installation

For the EVO I to III the EVOLink<sup>G3</sup> is designed to be installed in place of the printed circuit board in the factory ECU (these ECU's are in a metal enclosure). This creates a completely invisible install and eliminates the need to modify ECU mounting points. For EVO IV to VIII (ECU's in a plastic enclosure), the EVOLink<sup>G3</sup> is supplied in its own case that must be mounted in place of the factory ECU. For EVO IX the EVOLink<sup>G3</sup> is also supplied in its own case but also includes an AdaptaLink to allow the ECU to be connected to the car.

### **WARNING**

**The following installation process will require handling of both the Link ECU and factory ECU. Both of these are highly sensitive to electrostatic discharge and are easily damaged. Follow the anti-static precautions given in this manual carefully to avoid damaging electronic components. Warranty claims for ECU's damaged by electrostatic discharge will NOT be accepted.**

## ANTI-STATIC HANDLING GUIDELINES

Your body builds up an electrical charge as you move around. This charge can reach very high voltages. Whenever given the opportunity this energy will attempt to discharge (usually through your finger tips!). This can be fatal to most electronic components. Most people have experienced an electrostatic discharge when they step out of their car or touch a metal bench top.

The following guidelines describe precautions that can be taken to reduce the possibility of damaging your ECU:



1. Work only on a conductive surface. A clean steel bench is suitable.
2. Always wear a wrist strap that is electrically connected to the conductive working surface.
3. Touch the working surface regularly.
4. Do NOT touch components on the circuit board.
5. Where possible, only handle the ECU by its plastic header.
6. Do NOT carry the ECU around without static packaging (the black box supplied with the Link ECU is static protective).
7. Do NOT touch the bare terminals in the ECU header.

Observing the above procedures will minimise the chance of damaging both the factory and Link ECU's. Note that failure due to static damage often does not appear until well after it was caused.

## 2.2 Pre Installation Configuration

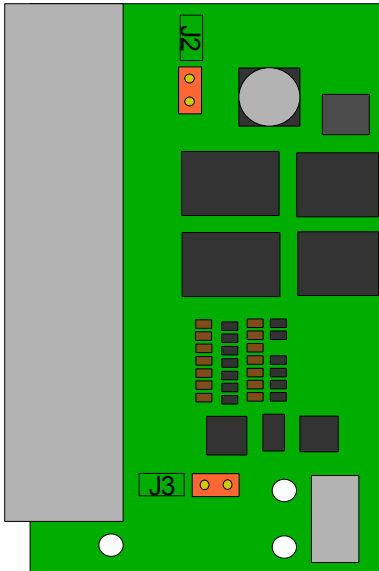
The EVOLink<sup>G3</sup> covers a large range of models. Over the years minor changes have been made to the factory ECU pin-out. To ensure the EVOLink<sup>G3</sup> is “wired” correctly for your vehicle configuration jumpers must be installed in the correct locations. The ECU is configured by installing the configuration jumpers as shown below:

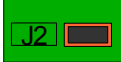
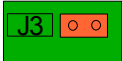

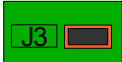
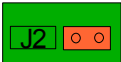
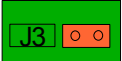
Model	J2	J3
EVO I EVO II EVO III	FIT  	REMOVE 
EVO IV EVO V EVO VI EVO VII	REMOVE 	FIT 
EVO VIII EVO IX	REMOVE 	REMOVE 

## 2.3 Installation Procedure (EVO I - III):

1.1.1 Note: EVO's I to III use a three plug ECU. The EVOLink<sup>G3</sup> has four plugs. Connect the three factory plugs to the appropriate ECU connector. The smallest plug in the EVOLink<sup>G3</sup> will be left unconnected.

1.1.2 Remove the factory ECU from the vehicle: **Ensure the key is in the OFF position.** The factory ECU is located on the left side A pillar. Remove the left kick panel. Unplug the wiring harness from the factory ECU (press the locking button on each connector while gently pulling on it). Remove the 6mm bolts (10mm socket) that retain the ECU and remove the ECU from the vehicle. **DO NOT** touch the exposed pins in the factory ECU connector.

1.1.3 Remove the factory ECU's circuit board from its enclosure: Ensure you are following the given anti-static guidelines and **ARE WEARING A CONDUCTIVE WRIST STRAP** connected to the working surface. Remove the top cover from the ECU enclosure by removing the four retaining screws. Remove the circuit board by removing four corner screws. Hold it only by the plastic header and place it aside.

1.1.4 Fit the Link Plug-In ECU: Remove the Link ECU from its packaging and place it immediately in the ECU enclosure. Place the factory ECU in the packaging your Link ECU came in for its protection. It may be necessary to break off the six small tabs on the sides of the circuit board.

1.1.5 Modify the enclosure top cover. Widen the ECU header slot. Also leave room to allow the ECU header USB tuning cable to exit the enclosure. **DO NOT** roll up the USB tuning cable and tuck it inside the enclosure (rather remove it completely if need be). Ensure that any slot or hole cut in the top cover will not eventually cut into the USB tuning cable.

1.1.6 Fit the ECU back to the vehicle: Fit the ECU back into the vehicle in the reverse order to which it was removed (remember only three of the four plugs will be used).

**1.1.7 Do not attempt to start the vehicle until ALL the setup procedures in this manual have been completed.**

## 2.4 Special Installation Instructions for EVO III

Some EVO III models have an additional wire fitted in the ECU header that must be removed at installation. If this wire is not removed the symptom will be that the wastegate solenoid is energised all the time. **This is a dangerous situation as boost will be allowed to reach its maximum value therefore this wire must be cut or removed.** The following diagram shows where to find the offending wire (pin 11 – Viewed looking into the ECU's main header).

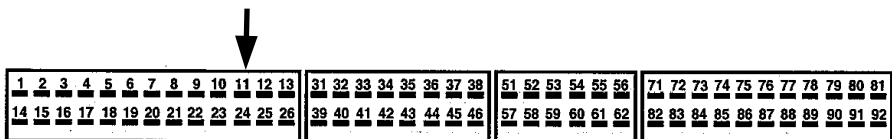

## 2.5 Installation Procedure (EVO IV – VIII):

Remove the factory ECU from the vehicle: **Ensure the key is in the OFF position.** The factory ECU is located behind the glove box. Remove glove box. Unplug the wiring harness from the factory ECU (press the locking button on each connector while gently pulling on it). Remove the 6mm bolts (10mm socket) that retain the ECU and remove the ECU from the vehicle. **DO NOT** touch the exposed pins in the factory ECU connector.

Remove the metal ECU mounting bracket.

Mount the EVOLink<sup>G3</sup> on the metal mounting bracket. In some cases it may be necessary to modify the bracket to fit. Refit the metal mounting bracket and EVOLink<sup>G3</sup> ECU.

Connect the wiring harness to the ECU.

**Do not attempt to start the vehicle until ALL the setup procedures in this manual have been completed.**

## 2.6 Installation Procedure (EVO IX):

Remove the factory ECU from the vehicle: **Ensure the key is in the OFF position.** The factory ECU is located behind the glove box. Remove glove box. Unplug the wiring harness from the factory ECU (press the locking button on each connector while gently pulling on it). Remove the 6mm bolts (10mm socket) that retain the ECU and remove the ECU from the vehicle. **DO NOT** touch the exposed pins in the factory ECU connector.

Connect the AdaptaLink to the vehicles wiring harness. Connect the EVOLink<sup>G3</sup> ECU to the AdaptaLink using the supplied short harness.

Mount the ECU and AdaptaLink in a secure location behind the glove box.

**Do not attempt to start the vehicle until ALL the setup procedures in this manual have been completed.**

## 2.7 Map Sensor Installation

A Manifold Absolute Pressure (MAP) sensor is supplied and must be connected both electrically and pneumatically. Since the EVOLink does not use the air flow meter, the MAP power supply and signal return use the air flow meters unused wiring. This avoids the need to run extra wires into the engine bay.

Note: Some models of EVO IX have a MAP sensor factory fitted to the intake manifold. This map sensor is suitable for use with the EVOLink<sup>G3</sup> therefore external MAP sensor installation is not required.

**The MAP signal replaces the AFM signal to the ECU. The MAP sensors signal wire is connected the the AFM's signal wire.**

Mount the supplied MAP sensor in a convenient location, keeping the pressure tube and wiring lengths as short as possible. Do not mount the MAP sensor directly on the engine or in a location subject to high vibration or heat levels (such as near the exhaust).

Using the supplied vacuum hose, plumb the MAP sensors pressure port to a source of vacuum/boost. This will normally be in the plenum chamber region, after the throttle plate. Do not be tempted to 'T' into an

unknown vacuum line. Ideally the MAP sensor should be connected to its own port in the plenum chamber. A “T” into the fuel pressure regulator vacuum/pressure line is also suitable.

The MAP sensor will be wired to the original air flow meter wiring. MAP sensor wires must be properly soldered and insulated. It is recommended that the MAP wires are soldered to the air flow meter wires approximately 30 mm behind the air flow meter connector. It is not necessary to cut the wires, but rather strip back a 10 mm section of insulation. Figure 2.1 shows wiring connections:

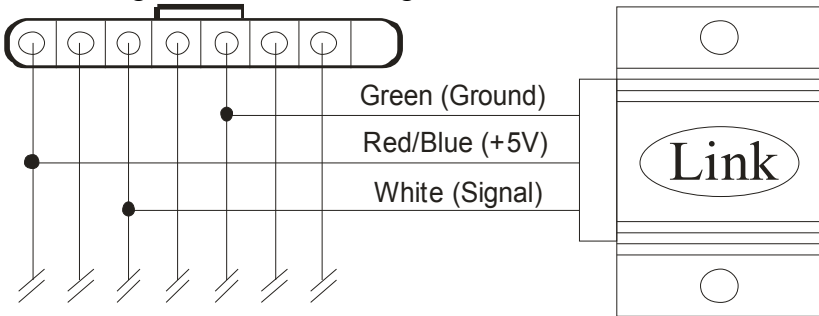

Looking into **back** (wire side) of the Air Flow Meter Connector

EVO I to III

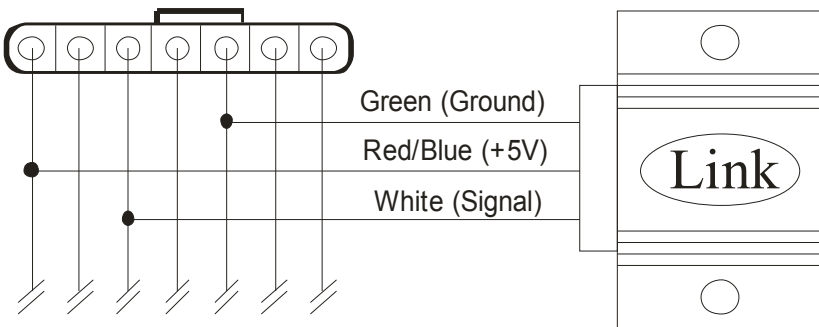

Looking into **back** (wire side) of the Air Flow Meter Connector

EVO V and EVO IX

## Figure 2.1 – MAP Sensor Wiring Connections

After wiring is completed, it is essential that the air flow meter connector is tied back in a manner that makes it impossible for it to be connected back to the air flow meter. Connecting both the MAP Sensor and air flow meter could result in damage to the air flow meter or MAP Sensor and will result in tuning problems that could cause engine damage.

## 2.8 Intake Air Temp Sensor Installation

An Intake Air Temperature (IAT) sensor is supplied and must be connected electrically and installed in the intake system. Since the EVOLink does not use the air flow meter, the IAT sensor uses the air flow meters unused wiring. This avoids the need to run extra wires into the engine bay.

Note: Some models of EVO IX have an IAT sensor factory fitted to the intake manifold. This map sensor is suitable for use with the EVOLink<sup>G3</sup> therefore external IAT sensor installation is not required.

**The IAT signal replaces the AFM's IAT signal to the ECU. The IAT sensors signal wire is connected the the AFM's IAT signal wire.**

The IAT Sensor must always be installed to take advantage of the EVOLink's air temperature correction features. The best state of tune can not be achieved without intake temperature correction.

*Note: Installation of the IAT sensor will require modification to the intake system pipes. A threaded boss must be welded into the intake pipes. This requires correct equipment and should only be performed*

*by a professional installer.*

Install the IAT sensor in the intake system between the throttle body and intercooler outlet. The sensor should be installed as close as is practical to the throttle body.

The IAT sensor will be wired to the original air flow meter wiring. IAT sensor wires must be properly soldered and insulated. It is recommended that the IAT wires are soldered to the air flow meter wires approximately 30 mm behind the air flow meter connector. It is not necessary to cut the wires, but rather strip back a 10 mm section of insulation. Figure 2.2 shows wiring connections:

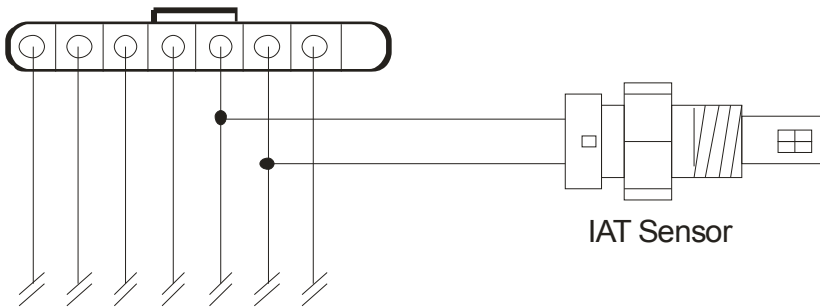

Looking into **back** (wire side) of the Air Flow Meter Connector

EVO I to III

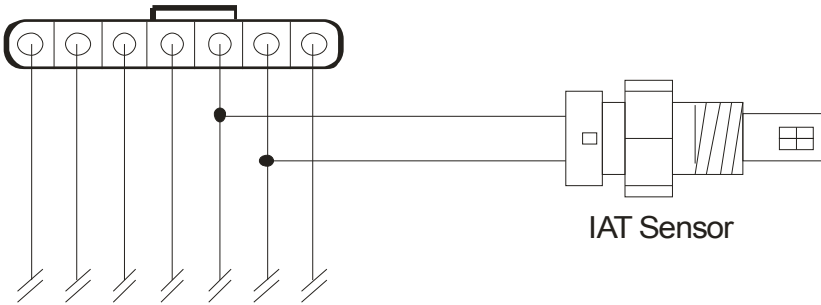

Looking into **back** (wire side) of the Air Flow Meter Connector

## EVO V and EVO IX

### **Figure 2.2** – IAT Sensor Wiring Connections

After wiring is completed, it is essential that the air flow meter connector is tied back in a manner that makes it impossible for it to be connected back to the air flow meter. Connecting both the IAT Sensor and air flow meter could result in damage to the air flow meter and will result in tuning problems that could cause engine damage.

## 3 FIRST TIME SETUP

Although Link ECU's come with base settings that allow the engine to be started, ALL Link ECU's must be professionally tuned immediately after installation. Failing to have the ECU correctly tuned for your vehicle could result in engine damage or violation of emissions laws.

### 3.1 CONNECTING TO PCLINK

PCLink is Link ElectroSystems Ltd. ECU tuning software. This software must be installed on a Windows based laptop/notebook before any adjustments or tuning can be performed. The latest version of

PCLink will be require to tune you Link ECU and is freely available for download from:

[www.linkecu.com](http://www.linkecu.com)

Link G3 ECU's come with on board USB support. Installation of PCLink installs the required USB driver software. You MUST do a complete install of PCLink before connecting the ECU to the PC for the first time.

After installing the latest version of PCLink (which installs the Link USB drivers), the ECU can be connected to the PC. Connect the ECU to the PC using the supplied USB cable as shown in Figure 3.1. Note that the cables fitted with an orange O'ring are USB cables.

After connecting the ECU to the PC, run PCLink (an icon should have been placed on your PC's desktop).

Under the 'Options' menu select the correct COM port for communications with the Link ECU. If the COM port number is unknown, it may be necessary to test all available COM ports until the correct one is found. Select 'OK' to close the 'Options' window.

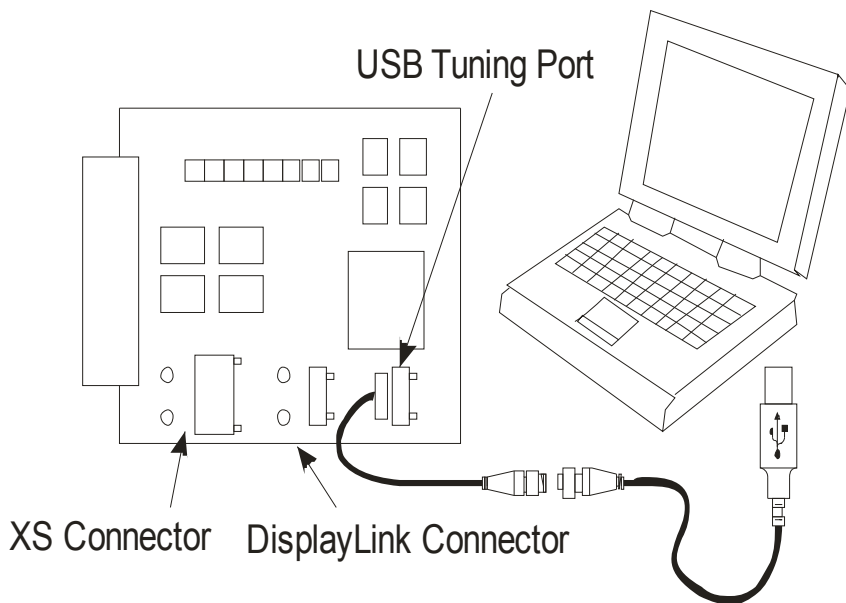

**Figure 3.1** – EVOLink<sup>G3</sup> Tuning Cable Connection

To connect to the Link ECU, turn on the ignition switch then click on the L symbol (top center of screen). All settings should now be loaded from the ECU and the Link logo in the top right corner of the screen should be spinning to indicate communications are OK. If an error occurs during connection, recheck all wiring connections and ensure the correct COM port is selected.

If connection can not be established, contact one of the support options given in Section 1 of this manual.

**Help on individual tuning functions is available through the PCLink on line help (Press F1, or right click on any item and select 'Whats This?').**

## 3.2 INITIAL ADJUSTMENTS

It is important that the procedures described in the following sections are followed before the Link ECU is tuned.

### BASE CONFIGURATION

All EVOLink G3 ECU's are shipped with base configuration settings. Note that these are provided to reduce initial setup and tuning times. They are NOT recommended tuning values. PCLink includes base configurations for all EVO models. Download the appropriate base configuration into your ECU with PCLink by connecting to the ECU using PCLink as described in Section 3.1, then selecting 'Open' under the 'File' menu. Select the appropriate .pcl file and then select 'Open'. Downloading large configuration files can take up to a few minutes. Be patient and acknowledge any messages PCLink shows.

### MAP SENSOR CALIBRATION

The following procedure must be performed before tuning to ensure that the MAP Sensor is correctly calibrated. This is done by calibrating the MAP sensor to the ECU's internal Barometric Absolute Pressure (BAP) sensor. The BAP sensor is calibrated before the ECU is shipped. To calibrate the MAP sensor:

1. Connect a laptop/notebook PC to the ECU and connect to the ECU using PCLink as described in Section 3.1.
2. Under the 'Options' menu, select 'MAP sensor calibration'.
3. Follow the on screen instructions.

4. Select the 'Analog Inputs' tab in the runtime values section of PCLink (lower part of the screen).
5. Compare the MAP and BAP values and ensure they have a similar reading (within 1 kPa).
6. Perform a 'Store' by clicking on the S button (top center of screen) and clicking OK.

## TPS CALIBRATION

The Throttle Position Sensor (TPS) is used by the ECU to calculate various engine management parameters. It is important that the ECU knows when the throttle is open and closed (or part way in between). The following procedure calibrates the ECU to match the TPS:

1. Connect a laptop/notebook PC to the EVOLink G3 and connect to the ECU using PCLink as described in Section 3.1.
2. Under the 'Options' menu, select 'TPS calibration'.
3. Follow the on screen instructions.
4. Select the 'Analog Inputs' tab in the runtime values section of PCLink (lower part of the screen).
5. Ensure the Throttle Position value reads 0% when the throttle is closed and 100% when fully open.
7. Perform a 'Store' by clicking on the S button (top centre of screen) and clicking OK.

## IAT SENSOR SELECTION

Where a MAF meter (Air Flow Meter) is not being used, an Intake Air Temperature (IAT) sensor (installed in Section 2) is used by the Link ECU to calculate fueling corrections based on the engines intake air temperature. It is important that the EVOLink G3 is calibrated to match the sensor installed in the engine. This procedure is as simple as selecting the correct sensor type as follows:

1. Connect a laptop/notebook PC to the EVOLink G3 and connect to the ECU using PCLink as described in Section 3.1.
2. Click on 'Analogue Channel' in the configuration tree (white area in top left corner).
3. Click on 'ANTemp2' in the configuration tree.
4. Ensure 'Temp Channel #2' is set to 'Inlet Air Temperature'.
5. Select the correct 'Temp Sensor Type'.
6. Select the 'Analog Inputs' tab in the runtime values section of PCLink (lower part of the screen).
7. Ensure that IAT reads the correct temperature.
8. Perform a 'Store' by clicking on the S button (top centre of screen) and clicking OK.

## 4 – EVOLINK<sup>G3</sup> EXCESS (XS) CONNECTOR

---

As most of the EVOLink's input and output pins are configurable, these pins can be used to connect other devices simply by re-wiring them (eg if air con is no longer fitted, the air con clutch output could be used to drive a shift light).

To reduce the need for modification of the factory loom, some Link Plug-In ECU's have a connector that allows expansion of the ECU's input and output capabilities. The EVOLink's XS connector is located on the circuit board as shown in Figure 3.1. This connector allows the following additional inputs to be connected:

- 1 x Analog Voltage Input (AN1 Volt) – 0-5V for wide band Lambda, pressure etc...
- 1 x Analog Temperature Input (AN4 Temp) – Input for thermistor temperature sensor.
- 2 x Digital Inputs (DI7 and DI8) – Digital Inputs for switches or speed sensors etc...

The EVOLink's XS connector does not have any additional output pins as these are all used by other functions.

As it is seldom used, the EVOLink<sup>G3</sup> is not shipped with the XS connector wiring loom. Contact your nearest Link dealer to purchase a loom. Wiring instructions are included with the loom.

### **Note:**

Do NOT attempt to connect anything to the EVOLink XS connector without using the purpose built wiring loom. Doing so may result in permanent damage to your Link ECU.

# APPENDIX A – DEFAULT CONFIGURATION

---

The following table is a summary of the EVOLinkG3 input/output default configuration:

<b>EVO I, EVO II, EVO III</b>	
<b>Auxiliary Drivers</b>	
Aux 1	Engine Fan
Aux 2	N/C
Aux 3	Tachometer
Aux 4	Boost Control Solenoid
Aux 5	Idle Step A
Aux 6	Idle Step B
Aux 7	Idle Step C
Aux 8	Idle Step D
Aux 9	Front Oxygen Sensor Heater
Aux 10	I/C Spray Lamp
Aux 11	N/C
<b>Digital Inputs</b>	
DI 1	Road Speed
DI 2	Start Signal
DI 3	N/C
DI 4	Air Con Request
DI 5	N/C
DI 6	Ignition Switch Input
DI 7	XS Connector
DI 8	XS Connector
DI 9	Power Steer Switch
DI 10	N/C
DI 11	Alternator G Terminal
DI 12	N/C

## Analog Inputs

An Temp 1	Engine Temperature
An Temp 2	Inlet Air Temperature
An Temp 3	Fuel Temperature
An Temp 4	XS Connector
An Volt 1	XS Connector
An Volt 2	Front Oxygen Sensor Signal
An Volt 3	Rear Oxygen Sensor Signal (if fitted)
An Volt 4	MAF Sensor Barometric Pressure
An Volt 5	N/C
An Volt 6	N/C
Load 1	MAP
Load 2	MAF
Load 3	TPS

## Ignition Channels

Ignition 1	Cylinder 1/4 Igniter
Ignition 2	Cylinder 2/3 Igniter
Ignition 3	A/C Clutch
Ignition 4	Catalytic Converter Temp. Light
Ignition 5	MIVEC
Ignition 6	N/C
Ignition 7	N/C
Ignition 8	N/C

## Injection Channels

Injection 1	Cylinder 1 Injector
Injection 2	Cylinder 2 Injector
Injection 3	Cylinder 3 Injector
Injection 4	Cylinder 4 Injector
Injection 5	Main Relay Control
Injection 6	N/C
Injection 7	Fuel Pump Relay
Injection 8	Fan Speed Relay

## EVO IV, EVO V, EVO VI

### Auxiliary Drivers

Aux 1	Engine Fan (Low Speed)
Aux 2	Secondary Air Solenoid
Aux 3	Tachometer
Aux 4	Boost Control Solenoid
Aux 5	Idle Step A
Aux 6	Idle Step B
Aux 7	Idle Step C
Aux 8	Idle Step D
Aux 9	Front Oxygen Sensor Heater
Aux 10	I/C Spray Lamp
Aux 11	Engine Fan High Speed

### Digital Inputs

DI 1	Road Speed
DI 2	Start Signal
DI 3	N/C
DI 4	Air Con Request
DI 5	N/C
DI 6	Ignition Switch Input
DI 7	XS Connector
DI 8	XS Connector
DI 9	Power Steer Switch
DI 10	N/C
DI 11	Alternator G Terminal
DI 12	Idle Switch

### Analog Inputs

An Temp 1	Engine Temperature
An Temp 2	Inlet Air Temperature
An Temp 3	Fuel Temperature

An Temp 4	XS Connector
An Volt 1	XS Connector
An Volt 2	Front Oxygen Sensor Signal
An Volt 3	Rear Oxygen Sensor Signal (if fitted)
An Volt 4	MAF Sensor Barometric Pressure
An Volt 5	N/C
An Volt 6	N/C
Load 1	MAP
Load 2	MAF
Load 3	TPS

### **Ignition Channels**

Ignition 1	Cylinder 1/4 Igniter
Ignition 2	Cylinder 2/3 Igniter
Ignition 3	A/C Clutch
Ignition 4	Catalytic Converter Temp. Light
Ignition 5	Fuel Pump Speed
Ignition 6	MAF Reset
Ignition 7	Condenser Fan Relay (Some models)
Ignition 8	I/C Spray Relay

### **Injection Channels**

Injection 1	Cylinder 1 Injector
Injection 2	Cylinder 2 Injector
Injection 3	Cylinder 3 Injector
Injection 4	Cylinder 4 Injector
Injection 5	Main Relay Control
Injection 6	Secondary Air Control Solenoid
Injection 7	Fuel Pump Relay
Injection 8	Fuel Pressure Regulator Bypass

## EVO VII, EVO VIII

### Auxiliary Drivers

Aux 1	N/C
Aux 2	EGR
Aux 3	Tachometer
Aux 4	Boost Control Solenoid
Aux 5	Idle Step A
Aux 6	Idle Step B
Aux 7	Idle Step C
Aux 8	Idle Step D
Aux 9	Front Oxygen Sensor Heater
Aux 10	I/C spray Lamp
Aux 11	N/C

### Digital Inputs

DI 1	Road Speed
DI 2	Start Signal
DI 3	Fuel Tank Pressure
DI 4	Air Con Request
DI 5	I/C Spray Request (Manual)
DI 6	Ignition Switch Input
DI 7	XS Connector
DI 8	XS Connector
DI 9	Power Steer Switch
DI 10	I/C Spray Request (Auto)
DI 11	Alternator G Terminal
DI 12	N/C

### Analog Inputs

An Temp 1	Engine Temperature
An Temp 2	Inlet Air Temperature
An Temp 3	Fuel Temperature

An Temp 4	XS Connector
An Volt 1	XS Connector
An Volt 2	Front Oxygen Sensor Signal
An Volt 3	Rear Oxygen Sensor Signal (if fitted)
An Volt 4	MAF Sensor Barometric Pressure
An Volt 5	N/C
An Volt 6	N/C
Load 1	MAP
Load 2	MAF
Load 3	TPS

### **Ignition Channels**

Ignition 1	Cylinder 1/4 Igniter
Ignition 2	Cylinder 2/3 Igniter
Ignition 3	A/C Clutch
Ignition 4	Purge Solenoid
Ignition 5	Fuel Pump Speed
Ignition 6	MAF Reset
Ignition 7	Condenser Fan Relay
Ignition 8	I/C Spray Relay

### **Injection Channels**

Injection 1	Cylinder 1 Injector
Injection 2	Cylinder 2 Injector
Injection 3	Cylinder 3 Injector
Injection 4	Cylinder 4 Injector
Injection 5	Main Relay Control
Injection 6	Secondary Air Solenoid (EVO IIV only)
Injection 7	Fuel Pump Relay
Injection 8	Fuel Pressure Regulator Bypass

## EVO IX

### Auxiliary Drivers

Aux 1	Engine Fan
Aux 2	VVT Control Solenoid
Aux 3	Tachometer
Aux 4	Boost Control Solenoid
Aux 5	Idle Step A
Aux 6	Idle Step B
Aux 7	Idle Step C
Aux 8	Idle Step D
Aux 9	Fan Relay High (Some models only)
Aux 10	Oxygen Sensor Heater
Aux 11	Fuel Pressure Regulator Bypass Solenoid

### Digital Inputs

DI 1	Road Speed
DI 2	VVT Cam Position
DI 3	A/C Switch (Temperature Dial)
DI 4	Alternator FR Terminal
DI 5	A/C Request Switch
DI 6	Ignition Switch Input
DI 7	I/C Manual Switch
DI 8	I/C Auto Switch
DI 9	Power Steer Switch
DI 10	Start Switch
DI 11	N/C
DI 12	N/C

### Analog Inputs

An Temp 1	Engine Temperature
An Temp 2	Inlet Air Temp. (Plenum Temp)
An Temp 3	Inlet Air Temp. (AFM or external IAT)

An Temp 4	N/C
An Volt 1	Oxygen Sensor Signal
An Volt 2	Barometer Voltage (from AFM)
An Volt 3	N/C
An Volt 4	N/C
An Volt 5	N/C
An Volt 6	N/C
Load 1	AFM Signal or External MAP Signal
Load 2	MAP (factory fitted sensor in plenum)
Load 3	TPS

### **Ignition Channels**

Ignition 1	Cylinder 1/4 Igniter
Ignition 2	Cylinder 2/3 Igniter
Ignition 3	Fuel Pump
Ignition 4	Condenser Fan Relay 2
Ignition 5	Condenser Fan Relay 1
Ignition 6	Secondary Air Solenoid
Ignition 7	CE Lamp
Ignition 8	Fuel Pump Speed Relay

### **Injection Channels**

Injection 1	Cylinder 1 Injector
Injection 2	Cylinder 2 Injector
Injection 3	Cylinder 3 Injector
Injection 4	Cylinder 4 Injector
Injection 5	I/C Spray Relay
Injection 6	I/C Spray Lamp
Injection 7	A/C Relay
Injection 8	Main Engine Relay