

The logo for EVOLink G2 Engine Management is contained within a dark green oval. The text 'EVOLink' is in a large, white, serif font, with 'G2' in a smaller, white, sans-serif font to its upper right. Below 'EVOLink' is the word 'Engine Management' in a white, serif font. At the bottom of the oval, the text 'Plug-in sequential fuel and ignition control' is written in a smaller, white, sans-serif font.

EVOLink G2
Engine Management
Plug-in sequential fuel and ignition control

By Link ElectroSystems Ltd.

INSTALLATION MANUAL

CONTENTS

1 – INTRODUCTION.....	3
1.1 – SAFETY FIRST.....	3
2 – INSTALLATION.....	4
2.1 – ECU INSTALLATION.....	4
2.2 – MAP SENSOR INSTALLATION.....	5
2.3 – INTAKE AIR TEMP SENSOR INSTALLATION.....	6
3 – FIRST TIME SETUP.....	7
3.1 – CONNECTION TO PCLINK.....	7
3.2 – INITIAL ADJUSTMENTS.....	8
3.2.1 – MAP SENSOR CALIBRATION.....	8
3.2.2 – TPS CALIBRATION.....	8
3.2.3 – IAT SENSOR SELECTION.....	9
APPENDIX A – DEFAULT CONFIGURATION.....	10

1 – INTRODUCTION

Thank you for purchasing your Link Electrosystems EVOLink G2. The EVOLink G2 is an advanced, fully programmable Engine Management System. The EVOLink G2 is the second generation of the successful EVOLink (G1) based on the new G2 software platform.

The G2 software platform boasts an impressive list of features giving a new level of user adjustability. This allows the tuner to have complete control over the engine management system. G2 employs high resolution 440 zone fuel and ignition tables with configurable load and RPM centres. When coupled with four dimensional fuel and ignition mapping this gives an unprecedented level of tuning accuracy. Software is in field upgradeable. There is no need to return the unit for software updates.

All Link Plug-In Engine Management Systems are designed with minimum installation in mind. Link Plug-In systems replace the circuit board inside the factory ECU enclosure. This provides an unobtrusive means of fitting a fully programmable engine management system to your vehicle without any permanent modifications and a completely invisible install.

Link Engine Management Systems are designed with the final result in mind. Not only do they boast an impressive range of performance features, but are designed with a focus on safety, reliability and driveability. However, the ultimate success of your engine management upgrade is determined by how well the system is installed and tuned.

Link Electrosystems appreciates your custom and has full confidence that you will be satisfied with your engine management system upgrade. Should any issue arise or for technical assistance the following support options are available:

- Contact your nearest Link Dealer (a dealer list is available on our website).
- Link Electrosystems Website – www.link-electro.co.nz
- Technical Support Email - tech@link-electro.co.nz
- Online Discussion – forums.link-electro.co.nz

1.1 – SAFETY FIRST

The EVOLink G2 is designed to enhance the performance of your vehicle. However in all cases, your vehicle must be operated in a safe manner. Do not tune your vehicle while operating it on public roads. Obey road rules at all times.



Failure to follow all installation and operating instructions may result in damage to the EVOLink G2, personal injury, or harm to property.

2 – INSTALLATION

The following sections describe physical installation of the EVOLink G2 ECU and required sensors:

2.1 – ECU INSTALLATION

The EVOLink G2 is designed to be installed in place of the printed circuit board in the factory ECU. This creates a completely invisible install and eliminates the need to modify ECU mounting points.

The factory ECU is located on the passengers side, left kick panel area. Remove any necessary interior panels to obtain access to the ECU. Remove the two 6mm bolts (10mm socket) that retain the ECU. Remove the factory ECU. Note that several earth wires may be terminated under these bolts. It is essential that these earth wires are installed back in their correct locations.

Installation of the EVOLink G2 into the factory ECU enclosure necessitates exercising anti-static precautions. DO NOT under any circumstances handle the EVOLink G2 before reading the following anti-static handling guidelines.

Anti-static Handling Guidelines

1. Work only on a conductive surface. A clean steel bench is suitable.
2. Always wear a wrist strap that is electrically connected to the working surface.
3. Touch the working surface regularly.
4. Do not carry the ECU around without static packaging (the black box supplied with Link ECU's is static protective).
5. Do not touch bare terminals in the ECU's header.

Observing the above procedures will minimise the chance of damaging both the factory and Link ECU's. Note that failure due to static damage often does not appear until well after it was caused.

Observing the above anti-static precautions, remove the four screws retaining the enclosure lid. Remove the factory ECU circuit board by removing the four retaining screws.

Install the EVOLink G2 in place of the factory ECU circuit board. Do NOT fit the cover to the ECU enclosure at this stage as access to the ECU's tuning port will be required.

Refit the ECU back to the vehicle, handling it only by the metal enclosure. Ensure all earth wires are correctly fitted.

After tuning has been performed, the ECU should be removed from the vehicle.

Observing the above static procedures, the small USB tuning adapter must be removed (do not cut a hole and leave hanging out). Refit the lid to the ECU enclosure and permanently install the ECU back in the vehicle.

2.2 – MAP SENSOR INSTALLATION

A Manifold Absolute Pressure (MAP) sensor is supplied and must be connected both electrically and pneumatically. Since the EVOLink G2 does not use the air flow meter, the MAP power supply and signal return use the air flow meters unused wiring. This avoids the need to run extra wires into the engine bay.

Mount the supplied MAP sensor in a convenient location, keeping the pressure tube and wiring lengths as short as possible. DO NOT mount the MAP sensor directly on the engine or in a location subject to high vibration or heat levels (such as near the exhaust).

Using the supplied vacuum hose, plumb the MAP sensors pressure port to a source of vacuum/boost. This will normally be in the plenum chamber region, AFTER THE THROTTLE PLATE. Do not be tempted to 'T' into an unknown vacuum line. Ideally the MAP sensor should be connected to its own port in the plenum chamber. 'T'ing into the fuel pressure regulator vacuum/pressure line is also suitable.

The MAP sensor will be wired to the original air flow meter wiring. MAP sensor wires must be properly soldered and insulated. It is recommended that the MAP wires are soldered to the air flow meter wires approximately 30 mm behind the air flow meter connector. It is not necessary to cut the wires, but rather strip back a 10 mm section of insulation. Figure 2.1 shows wiring connections:

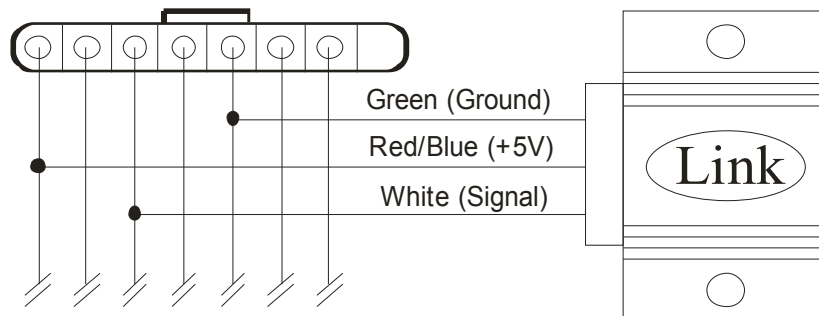

Looking into **back** (wire side) of the Air Flow Meter Connector

Figure 2.1 – MAP Sensor Wiring Connections

After wiring is completed, it is essential that the air flow meter connector is tied back in a manner that makes it impossible for it to be connected back to the air flow meter. Connecting both the MAP Sensor and air flow meter could result in damage to the air flow meter or MAP Sensor and will result in tuning problems that could cause engine damage.

2.3 – INTAKE AIR TEMP SENSOR INSTALLATION

An Intake Air Temp (IAT) sensor is supplied and must be connected electrically and installed in the intake system. Since the EVOLink G2 does not use the air flow meter, the IAT sensor uses the air flow meters unused wiring. This avoids the need to run extra wires into the engine bay.

The IAT Sensor must always be installed to take advantage of the EVOLink G2's air temperature correction features. The best state of tune can NOT be achieved without intake temperature correction.

Note: Installation of the IAT sensor will require modification to the intake system pipes. A threaded boss must be welded into the intake pipes. This requires correct equipment and should only be performed by a professional installer.

Install the IAT sensor in the intake system between the throttle body and intercooler outlet. The sensor should be installed as close as is practical to the throttle body.

The IAT sensor will be wired to the original air flow meter wiring. IAT sensor wires must be properly soldered and insulated. It is recommended that the IAT wires are soldered to the air flow meter wires approximately 30 mm behind the air flow meter connector. It is not necessary to cut the wires, but rather strip back a 10 mm section of insulation. Figure 2.2 shows wiring connections:

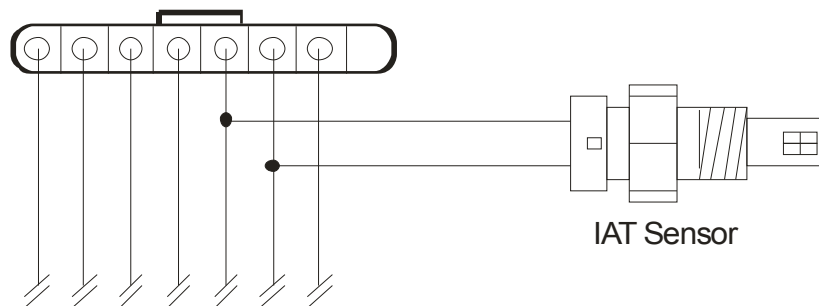

Looking into **back** (wire side) of the Air Flow Meter Connector

Figure 2.2 – IAT Sensor Wiring Connections

After wiring is completed, it is essential that the air flow meter connector is tied back in a manner that makes it impossible for it to be connected back to the air flow meter. Connecting both the IAT Sensor and air flow meter could result in damage to the air flow meter and will result in tuning problems that could cause engine damage.

3 – FIRST TIME SETUP

3.1 – CONNECTION TO PCLINK

PCLink is Link Electrosystems PC based tuning software. This software must be installed on a Windows based laptop/notebook PC before any adjustments or tuning can be performed. The latest version of PCLink is freely available for download from:

www.link-electro.co.nz

The EVOLink G2 comes with on board USB support. **BEFORE** connecting your EVOLink G2 to a laptop/notebook PC for the first time, the communications drivers must be installed. These drivers tell the PC how to talk to the EVOLink G2. USB Drivers for Link ECU's are also freely available for download from the above website.

Driver installation instructions are available from the above website (right next to the driver download) and should be followed closely. Should any problems arise, contact one of the support options given in Section 1 of this manual.

After installing both PCLink and the EVOLink G2 drivers, the ECU can now be connected to the PC. Connect the EVOLink G2's USB tuning cable to your laptop/notebook PC as shown in Figure 3.1 (Note: A commonly available USB extension cable will be required).

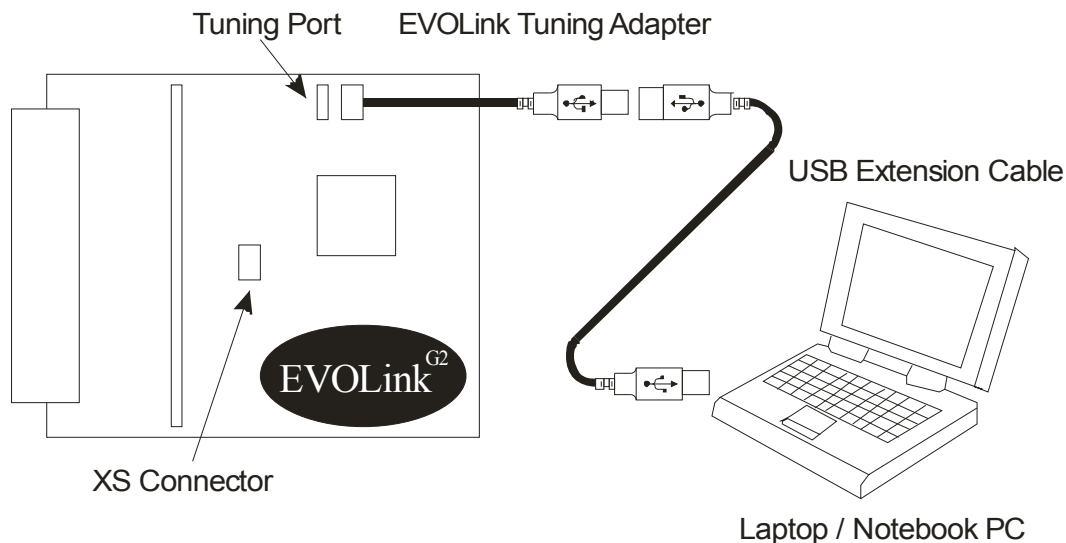

Figure 3.1 – EVOLink G2 Tuning Cable Connection

After connecting the EVOLink G2 to the PC, run PCLink. Under the 'Options' menu select the correct COM port for communications with the EVOLink. This COM port number should have been determined during the USB driver setup. If the COM port number is unknown, it may be necessary to try all COM ports until the correct one is found. Select 'OK' to close the 'Options' window.

To connect to the EVOLink G2, , click on the L symbol (top centre of screen). All settings should now be loaded from the EVOLink G2 and the Link logo in the top right corner of the screen should be spinning to indicate communications are OK. If an error occurs during connection, recheck all wiring connections and ensure the correct COM port is selected.

If connection can not be established, contact one of the support options given in Section 1 of this manual.

Note that help on individual tuning functions is available through the PCLink on line help.

3.2 – INITIAL ADJUSTMENTS

It is important that the procedures described in the following sections are followed before the EVOLink G2 is tuned.

3.2.1 – MAP SENSOR CALIBRATION

The following procedure must be performed before tuning to ensure that the MAP Sensor is correctly calibrated. This is done by calibrating the MAP sensor to the ECU's internal Barometric Absolute Pressure (BAP) sensor. The BAP sensor is calibrated before the ECU is shipped. To calibrate the MAP sensor:

1. Connect a laptop/notebook PC to the EVOLink G2 and connect to the ECU using PCLink as described in Section 3.1.
2. Under the 'Options' menu, select 'MAP sensor calibration'.
3. Follow the on screen instructions.
4. Select the 'Analog Inputs' tab in the runtime values section of PCLink (lower part of the screen).
5. Compare the MAP and BAP values and ensure they have a similar reading (within 1 kPa).
6. Perform a 'Store' by clicking on the S button (top centre of screen) and clicking OK.

3.2.2 – TPS CALIBRATION

The Throttle Position Sensor (TPS) is used by the ECU to calculate various engine management parameters. It is important that the ECU knows when the throttle is open and closed (or part way in between). The following procedure calibrates the ECU to match the TPS:

1. Connect a laptop/notebook PC to the EVOLink G2 and connect to the ECU using PCLink as described in Section 3.1.
2. Under the 'Options' menu, select 'TPS calibration'.
3. Follow the on screen instructions.
4. Select the 'Analog Inputs' tab in the runtime values section of PCLink (lower part of the screen).
5. Ensure the Throttle Position value reads 0% when the throttle is closed and 100%

when fully open.

7. Perform a 'Store' by clicking on the S button (top centre of screen) and clicking OK.

3.2.3 – IAT SENSOR SELECTION

The Intake Air Temperature (IAT) sensor (installed in Section 2) is used by the ECU to calculate fueling corrections based on the engines intake air temperature. It is important that the ECU is calibrated to match the sensor installed in the engine. This procedure is as simple as selecting the correct sensor type as follows:

1. Connect a laptop/notebook PC to the EVOLink G2 and connect to the ECU using PCLink as described in Section 3.1.
2. Click on 'Analogue Channel' in the configuration tree (white area in top left corner).
3. Click on 'ANTemp2' in the configuration tree.
4. Ensure 'Temp Channel #2' is set to 'Inlet Air Temperature'.
5. Select the correct 'Temp Sensor Type'.
6. Select the 'Analog Inputs' tab in the runtime values section of PCLink (lower part of the screen).
7. Ensure that IAT reads the correct temperature.
8. Perform a 'Store' by clicking on the S button (top centre of screen) and clicking OK.

4 - EVOLINK EXCESS (XS) CONNECTOR

Some Link Plug-In ECU's have a connector that allows expansion of the ECU's input and output capabilities. The EVOLink's XS connector is located on the circuit board as shown in Figure 3.1. The EVOLink's XS connector allows the following additional inputs to be connected:

- 2 x Analog Inputs – 0-5V for wide band Lambda, pressure etc...
- 2 x Digital Inputs – for switches (eg Antilag, launch etc...)
- 2 x Auxiliary Outputs – to drive solenoids, lights etc...

The EVOLink G2 is not shipped with the XS connector wiring loom. Contact your nearest Link dealer to purchase a loom. Wiring instructions are included with this loom.

Note:

Do NOT attempt to connect anything to the EVOLink G2's XS connector without using the purpose built wiring loom. Doing so may result in permanent damage to your Link ECU.

APPENDIX A – DEFAULT CONFIGURATION

The following table summarises the EVOLink G2 input/output default configuration:

Auxiliary Drivers	
Aux 1	Idle Speed Control (Stepper)
Aux 2	Fuel Pump
Aux 3	N/C
Aux 4	Waste Gate
Aux 5	XS Connector Aux Out 1
Aux 6	XS Connector Aux Out 2
Aux 7	N/C
Aux 8	AirCon Clutch
Aux 9	Engine Fan
Aux 10	N/C
Aux 11	CE Light
Aux 12	ISC Stepper Direction
Aux 13	AirCon Fan
Aux 14	N/C
Aux 15	N/C
Aux 16	N/C
Digital Inputs	
DI 1	Vehicle Speed
DI 2	XS Connector DI 1
DI 3	XS Connector DI 2
DI 4	Air Con Request
DI 5	N/C
DI 6	N/C
DI 7	N/C
DI 8	N/C
DI 9	N/C
DI 10	N/C
DI 11	N/C
DI 12	N/C
DI 13	Idle Switch
DI 14	Park/Neutral Switch
DI 15	Power Steer Switch
DI 16	Key On
Analog Inputs	
An Temp 1	Engine Temperature
An Temp 2	Inlet Air Temperature
Analog 1	Oxygen Sensor
Load 1	MAP
Load 2	TPS